

MWI

SECTION

METER, WARNING LAMP & INDICATOR

A
B
C
D
E
F
G
H
I
J
K
L
M
N
O
P

CONTENTS

PRECAUTION	3	METER ILLUMINATION CONTROL	13
PRECAUTIONS	3	METER ILLUMINATION CONTROL : System Description	14
Precaution for Supplemental Restraint System (SRS) "AIR BAG" and "SEAT BELT PRE-TENSIONER"	3	METER EFFECT FUNCTION	14
Precaution for Work	3	METER EFFECT FUNCTION : System Description	14
PREPARATION	4	INFORMATION DISPLAY	15
PREPARATION	4	INFORMATION DISPLAY : System Description	15
Special Service Tool	4	OPERATION	17
Commercial Service Tools	4	Switch Name and Function	17
SYSTEM DESCRIPTION	5	DIAGNOSIS SYSTEM (COMBINATION METER)	18
COMPONENT PARTS	5	On Board Diagnosis Function	18
METER SYSTEM	5	CONSULT Function (METER/M&A)	20
METER SYSTEM : Component Parts Location	5	ECU DIAGNOSIS INFORMATION	23
METER SYSTEM : Design	6	COMBINATION METER	23
METER SYSTEM : Combination Meter	7	Reference Value	23
METER SYSTEM : Steering Switches	7	Fail-safe	28
METER SYSTEM : Meter Control Switch	8	DTC Index	29
SYSTEM	9	BCM (BODY CONTROL MODULE)	30
METER SYSTEM	9	List of ECU Reference	30
METER SYSTEM : System Description	9	WIRING DIAGRAM	31
METER SYSTEM : Fail-safe	11	METER SYSTEM	31
SPEEDOMETER	12	Wiring Diagram	31
SPEEDOMETER : System Description	12	BASIC INSPECTION	42
TACHOMETER	12	DIAGNOSIS AND REPAIR WORK FLOW	42
TACHOMETER : System Description	13	Work flow	42
ENGINE COOLANT TEMPERATURE GAUGE	13	DTC/CIRCUIT DIAGNOSIS	45
ENGINE COOLANT TEMPERATURE GAUGE : System Description	13	U1000 CAN COMM CIRCUIT	45
FUEL GAUGE	13	DTC Description	45
FUEL GAUGE : System Description	13		

MWI

Diagnosis Procedure	45	Diagnosis Procedure	60
U1010 CONTROL UNIT (CAN)	46	THE OIL PRESSURE WARNING CONTIN-	UES DISPLAYING, OR DOES NOT DISPLAY... 61
DTC Description	46	Description	61
Diagnosis Procedure	46	Diagnosis Procedure	61
B2205 VEHICLE SPEED	47	THE PARKING BRAKE RELEASE WARNING	CONTINUES DISPLAYING, OR DOES NOT
DTC Description	47	DISPLAY	62
Diagnosis Procedure	47	Description	62
B2267 ENGINE SPEED	48	Diagnosis Procedure	62
DTC Description	48	THE LOW WASHER FLUID WARNING CON-	TINUES DISPLAYING, or DOES NOT DIS-
Diagnosis Procedure	48	PLAY	63
B2268 WATER TEMP	49	Description	63
DTC Description	49	Diagnosis Procedure	63
Diagnosis Procedure	49	THE DOOR OPEN WARNING CONTINUES	DISPLAYING, OR DOES NOT DISPLAY
POWER SUPPLY AND GROUND CIRCUIT	50	Description	64
COMBINATION METER	50	Diagnosis Procedure	64
COMBINATION METER : Diagnosis Procedure ...	50	THE TRUNK OPEN WARNING CONTINUES	DISPLAYING, OR DOES NOT DISPLAY
BCM (BODY CONTROL MODULE)	50	Description	65
BCM (BODY CONTROL MODULE) : Diagnosis		Diagnosis Procedure	65
Procedure	50	THE STEERING SWITCHES ARE INOPERA-	TIVE
METER CONTROL SWITCH SIGNAL CIR-	CUIT	Description	66
Diagnosis Procedure	52	Diagnosis Procedure	66
Component Inspection	53	THE AMBIENT TEMPERATURE DISPLAY IS	INCORRECT
FUEL LEVEL SENSOR SIGNAL CIRCUIT	54	Description	67
Component Function Check	54	Diagnosis Procedure	67
Diagnosis Procedure	54	REMOVAL AND INSTALLATION	68
Component Inspection	55	COMBINATION METER	68
WASHER FLUID LEVEL SWITCH CIRCUIT ...	56	Exploded View	68
Diagnosis Procedure	56	Removal and Installation	68
Component Inspection	56	METER CONTROL SWITCH	69
STEERING SWITCH	57	Removal and Installation	69
Diagnosis Procedure	57	UNIT DISASSEMBLY AND ASSEMBLY ...	70
Component Inspection	57	COMBINATION METER	70
SYMPTOM DIAGNOSIS	59	Disassembly and Assembly	70
THE FUEL GAUGE INDICATOR DOES NOT	OPERATE		
Description	59		
Diagnosis Procedure	59		
THE METER CONTROL SWITCH IS INOPER-	ATIVE		
Description	60		

PRECAUTIONS

< PRECAUTION >

PRECAUTION

PRECAUTIONS

Precaution for Supplemental Restraint System (SRS) "AIR BAG" and "SEAT BELT PRE-TENSIONER"

INFOID:000000012227879

The Supplemental Restraint System such as "AIR BAG" and "SEAT BELT PRE-TENSIONER", used along with a front seat belt, helps to reduce the risk or severity of injury to the driver and front passenger for certain types of collisions. Information necessary to service the system safely is included in the SR and SB sections of this Service Manual.

WARNING:

- To avoid rendering the SRS inoperative, which could increase the risk of personal injury or death in the event of a collision which would result in air bag inflation, all maintenance must be performed by an authorized NISSAN/INFINITI dealer.
- Improper maintenance, including incorrect removal and installation of the SRS, can lead to personal injury caused by unintentional activation of the system. For removal of spiral cable and air bag module, see the SR section.
- Do not use electrical test equipment on any circuit related to the SRS unless instructed to in this Service Manual. SRS wiring harnesses can be identified by yellow and/or orange harnesses or harness connectors.

PRECAUTIONS WHEN USING POWER TOOLS (AIR OR ELECTRIC) AND HAMMERS

WARNING:

- When working near the airbag diagnosis sensor unit or other airbag system sensors with the ignition ON or engine running, DO NOT use air or electric power tools or strike near the sensor(s) with a hammer. Heavy vibration could activate the sensor(s) and deploy the air bag(s), possibly causing serious injury.
- When using air or electric power tools or hammers, always switch the ignition OFF, disconnect the battery and wait at least three minutes before performing any service.

Precaution for Work

INFOID:000000012227880

- When removing or disassembling each component, be careful not to damage or deform it. If a component may be subject to interference, be sure to protect it with a shop cloth.
- When removing (disengaging) components with a screwdriver or similar tool, be sure to wrap the component with a shop cloth or vinyl tape to protect it.
- Protect the removed parts with a shop cloth and prevent them from being dropped.
- Replace a deformed or damaged clip.
- If a part is specified as a non-reusable part, always replace it with a new one.
- Be sure to tighten bolts and nuts securely to the specified torque.
- After installation is complete, be sure to check that each part works properly.
- Follow the steps below to clean components:
 - Water soluble dirt:
 - Dip a soft cloth into lukewarm water, wring the water out of the cloth and wipe the dirty area.
 - Then rub with a soft, dry cloth.
 - Oily dirt:
 - Dip a soft cloth into lukewarm water with mild detergent (concentration: within 2 to 3%) and wipe the dirty area.
 - Then dip a cloth into fresh water, wring the water out of the cloth and wipe the detergent off.
 - Then rub with a soft, dry cloth.
 - Do not use organic solvent such as thinner, benzene, alcohol or gasoline.
 - For genuine leather seats, use a genuine leather seat cleaner.

PREPARATION

< PREPARATION >

PREPARATION

PREPARATION

Special Service Tool

INFOID:000000012227881

The actual shape of the tools may differ from those illustrated here.

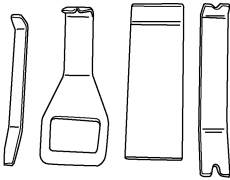
Tool number (TechMate No.) Tool name	Description
<p>— (J-46534) Trim tool set</p>  <p style="text-align: center;">AWJIA0483ZZ</p>	<p>Removing trim components</p>

Commercial Service Tools

INFOID:000000012227882

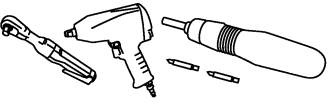
Tool name	Description
<p>Power tool</p>  <p style="text-align: center;">PIIB1407E</p>	<p>Loosening nuts, screws and bolts</p>

COMPONENT PARTS

< SYSTEM DESCRIPTION >

SYSTEM DESCRIPTION

COMPONENT PARTS

METER SYSTEM

METER SYSTEM : Component Parts Location

INFOID:000000012227883

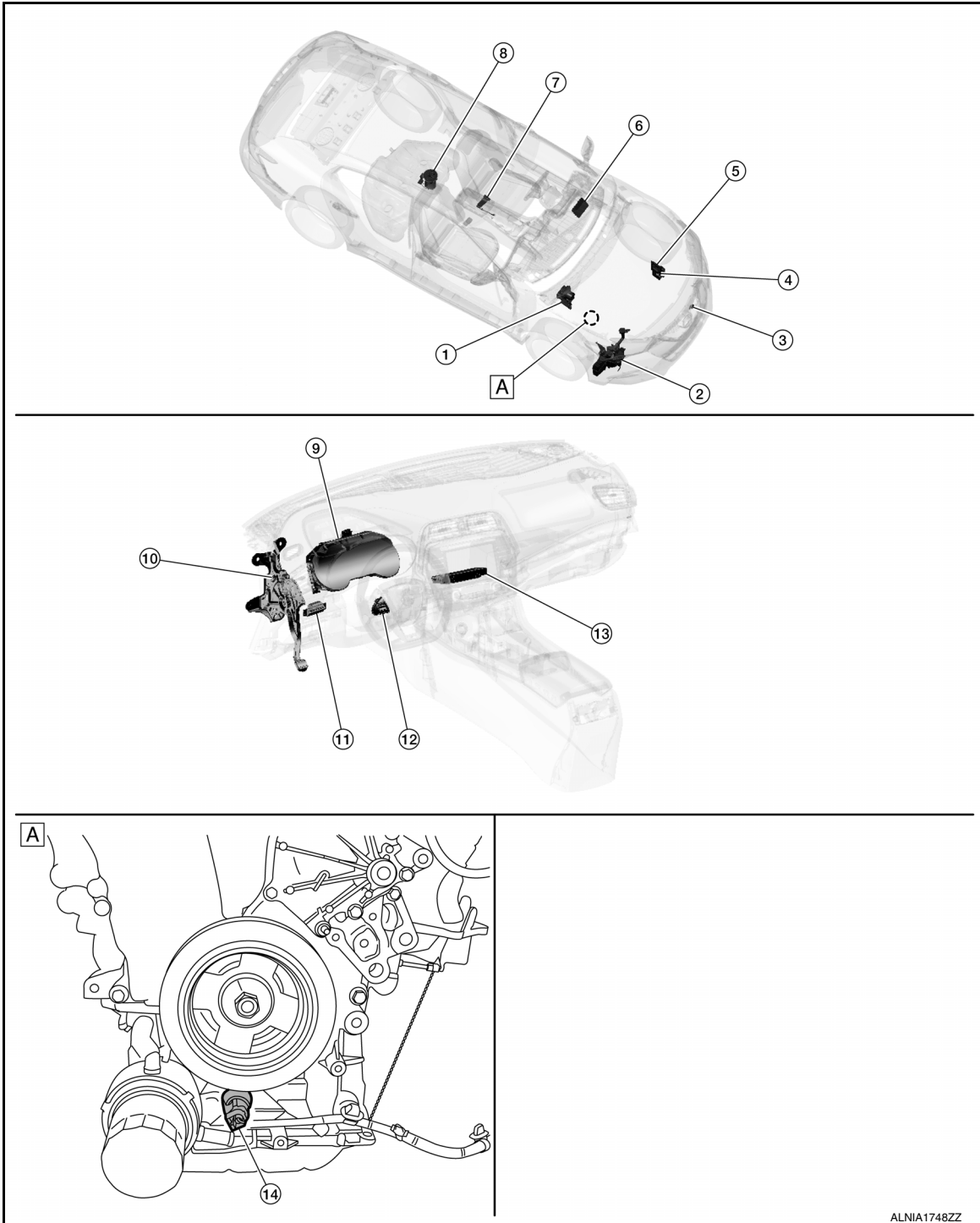

A. View of front engine assembly
(view with engine removed)

A
B
C
D
E
F
G
H
I
J
K
L
M
O
P

MWI

COMPONENT PARTS

< SYSTEM DESCRIPTION >

No.	Component	Function
1.	ABS actuator and electric unit (control unit)	<ul style="list-style-type: none"> • Transmits each signal to the combination meter via CAN communication. • Refer to BRC-184, "System Description" (with ICC) or BRC-14, "System Description" (without ICC). • Refer to BRC-10, "Component Parts Location" for detailed installation location.
2.	Washer fluid level switch	<ul style="list-style-type: none"> • Transmits the washer fluid level switch signal to the combination meter. • Refer to WW-6, "Component Parts Location" for detailed installation location.
3.	Ambient sensor	<ul style="list-style-type: none"> • Transmits the ambient sensor signal to the A/C auto amp. • Refer to HAC-9, "Component Parts Location" for detailed installation location.
4.	TCM	<ul style="list-style-type: none"> • Transmits each signal to the combination meter via CAN communication. • Refer to TM-27, "CVT CONTROL SYSTEM : System Description". • Refer to TM-12, "CVT CONTROL SYSTEM : Component Parts Location" for detailed installation location.
5.	ECM	<ul style="list-style-type: none"> • Transmits each signal to the combination meter via CAN communication. Refer to EC-33, "ENGINE CONTROL SYSTEM : System Description". • Refer to EC-15, "ENGINE CONTROL SYSTEM : Component Parts Location" for detailed installation location.
6.	BCM	<ul style="list-style-type: none"> • Transmits each signal to the combination meter via CAN communication. • Refer to BCS-7, "BODY CONTROL SYSTEM : System Description". • Refer to BCS-5, "BODY CONTROL SYSTEM : Component Parts Location" for detailed installation location.
7.	Seat belt buckle switch LH	Transmits the seat belt buckle switch LH signal to the combination meter.
8.	Fuel level sensor unit and fuel pump (fuel level sensor)	Transmits the fuel level sensor signal to the combination meter.
9.	Combination meter	Refer to MWI-9, "METER SYSTEM : System Description" .
10.	Parking brake switch	Transmits the parking brake switch signal to the combination meter.
11.	Meter control switch	Refer to MWI-17, "Switch Name and Function" .
12.	Steering switches	Refer to MWI-17, "Switch Name and Function" .
13.	A/C auto amp.	<ul style="list-style-type: none"> • Transmits the ambient sensor signal to the combination meter via CAN communication. • Refer to HAC-9, "Component Parts Location" for detailed installation location.
14.	Engine oil pressure sensor	Transmits the engine oil pressure sensor signal to the ECM.

METER SYSTEM : Design

INFOID:000000012227884

ARRANGEMENT OF COMBINATION METER

COMPONENT PARTS

< SYSTEM DESCRIPTION >

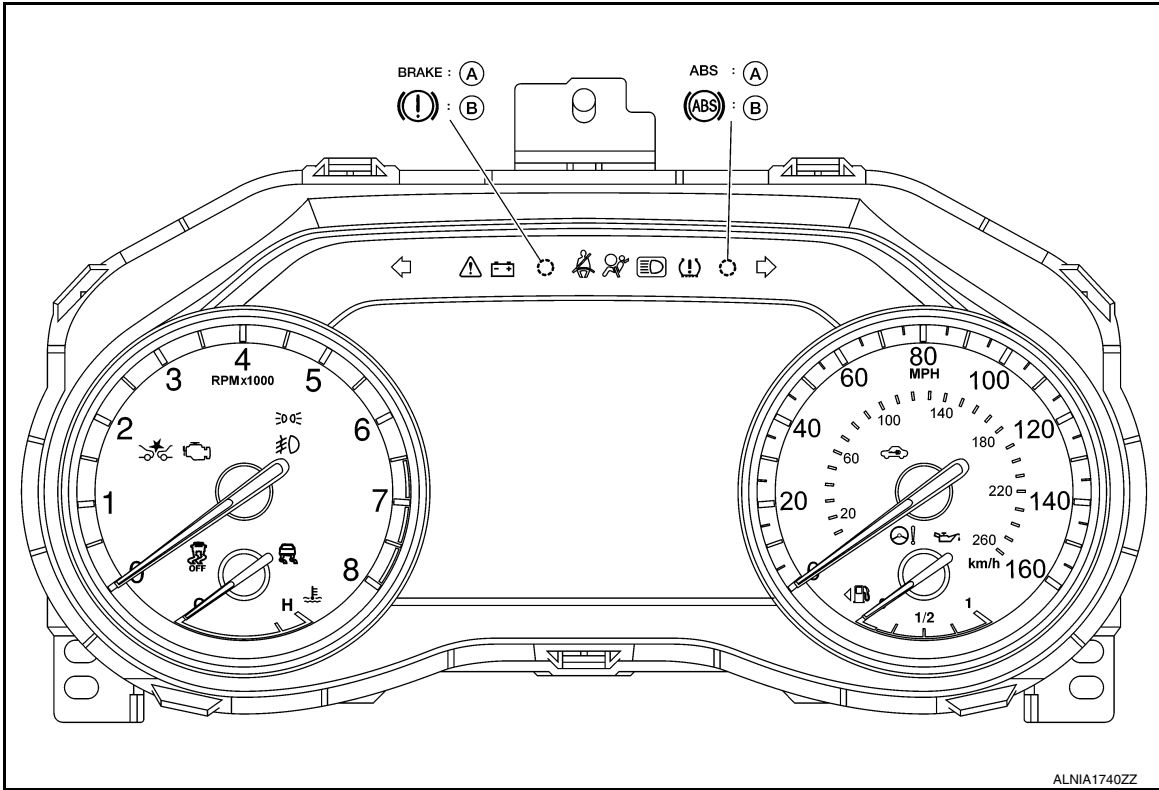

A: USA

B: Except USA

METER SYSTEM : Combination Meter

INFOID:000000012227885

The combination meter controls the following items according to the signals received from each unit via CAN communication and the signals from switches and sensors:

- Speedometer
- Tachometer
- Engine coolant temperature gauge
- Fuel gauge
- Indicator lamps
- Warning lamps
- Meter illumination control
- Meter effect function
- Information display

METER SYSTEM : Steering Switches

INFOID:000000012227886

- The steering switches are located on the steering wheel.
- The steering switch transmits the steering switch signal to the combination meter.

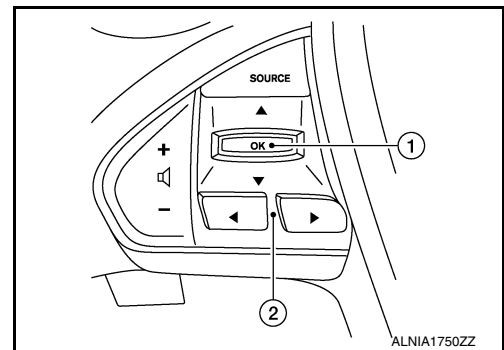

A
B
C
D
E
F
G
H
I
J
K
L
M
N
O
P

MWI

COMPONENT PARTS

< SYSTEM DESCRIPTION >

No.	Switch name	Operation	Description
1.	Enter/Up/Down switch	Press	The information display settings can be changed.
2.	Back or forward switch		

METER SYSTEM : Meter Control Switch

INFOID:000000012227887

- The meter control switch is located on the instrument lower panel LH.
- The meter control switch transmits the following signals to the combination meter:
 - Trip reset switch signal
 - Illumination control switch signal (+)
 - Illumination control switch signal (-)

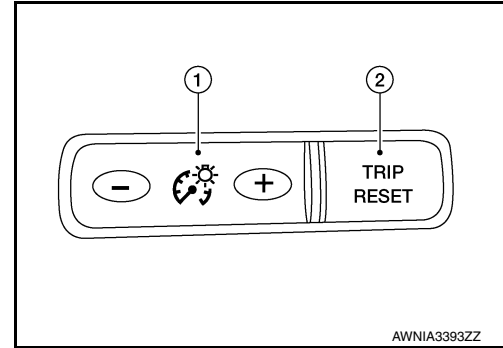

No.	Switch name	Operation	Description
1.	Illumination control switch	Press	The illumination level of the back light of the combination meter can be adjusted.
2.	Trip reset switch	Press	<ul style="list-style-type: none"> • The trip meter can be switched between A and B. • Trip meter A/B can be reset by pressing and holding the trip reset switch. • A trip computer value displayed on the information display can be reset by pressing and holding the trip reset switch for 1 second or more. • All trip computer values can be reset by pressing and holding the trip reset switch for 3 seconds or more.

SYSTEM

< SYSTEM DESCRIPTION >

SYSTEM

METER SYSTEM

METER SYSTEM : System Description

INFOID:000000012227888

SYSTEM DIAGRAM

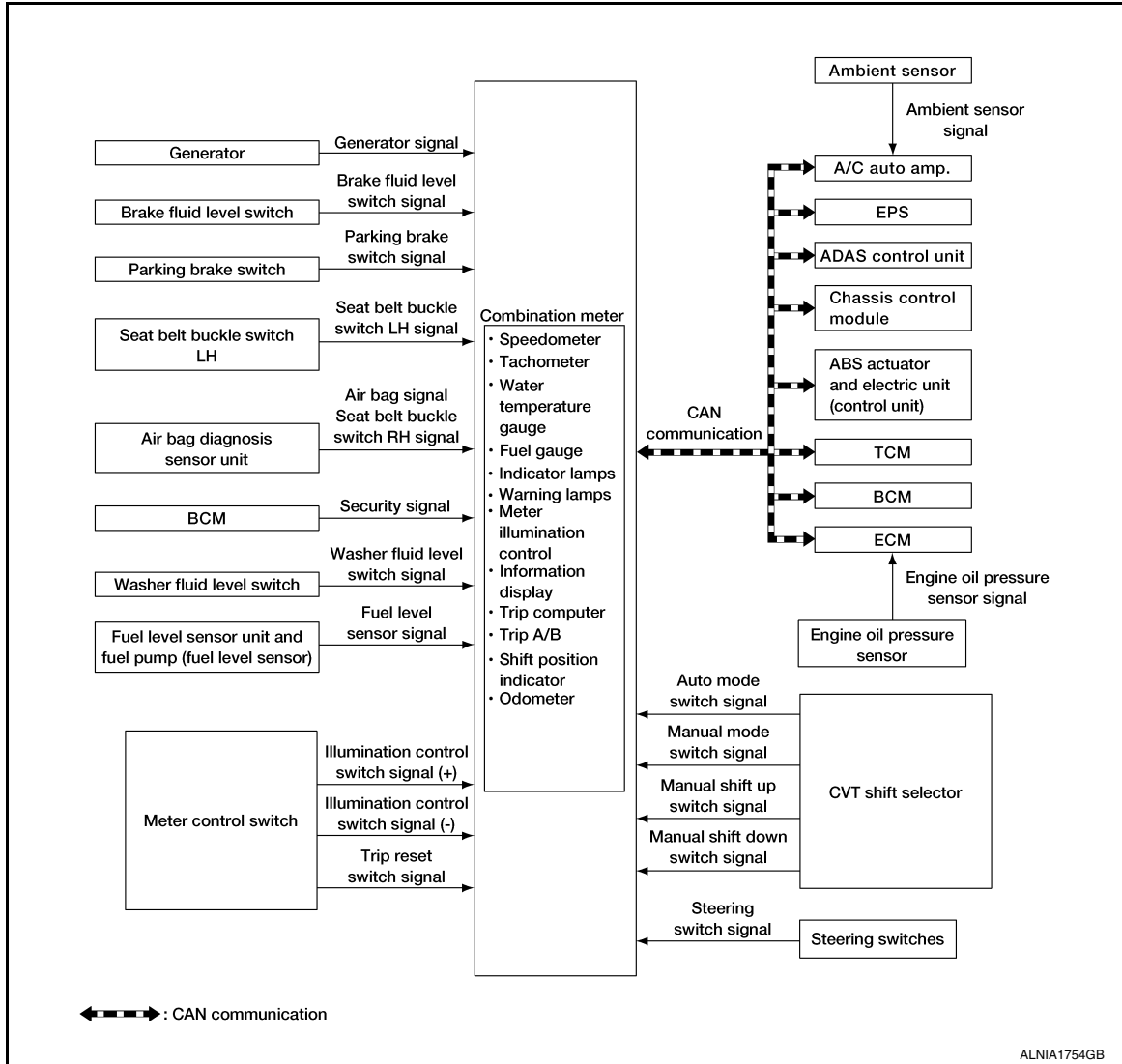

Combination Meter Input Signal (CAN Communication Signal)

Transmit unit	Signal name
ABS actuator and electric unit (control unit)	Vehicle speed signal
	ABS warning lamp signal
	VDC warning lamp signal
	VDC OFF indicator lamp signal
	Brake warning lamp signal

SYSTEM

< SYSTEM DESCRIPTION >

Transmit unit	Signal name
BCM	Dimmer signal
	Position light request signal
	Door switch signal
	Trunk switch signal
	Front fog light request signal
	High beam request signal
	Meter display signal
	Sleep wake up signal
	Buzzer output signal
	Tire pressure data signal
	Key ID signal
	Turn indicator signal
	TPMS malfunction warning lamp signal
	Starter relay status signal
Low tire pressure warning lamp signal	
TCM	Shift position signal
	CVT error warning lamp signal
ECM	Engine speed signal
	ASCD status signal
	Engine coolant temperature signal
	Fuel consumption monitor signal
	Malfunctioning indicator lamp signal
	Engine status signal
	Engine oil pressure sensor signal
Fuel-filler cap warning display signal	
Chassis control module	Active ride control signal
	Active trace control signal
	Active engine brake control signal
	Chassis control system error signal
A/C auto amp.	Ambient sensor signal
ADAS control unit	BSW warning lamp signal
	ICC warning lamp signal
	FEB warning lamp signal

DESCRIPTION

Combination Meter

The combination meter controls the following items according to the signals received from each unit via CAN communication and the signals from switches and sensors:

- Speedometer
- Tachometer
- Engine coolant temperature gauge
- Fuel gauge
- Warning lamps
- Indicator lamps
- Meter illumination control
- Meter effect function
- Information display

SYSTEM

< SYSTEM DESCRIPTION >

The combination meter incorporates a buzzer function that sounds an audible alarm with the integrated buzzer. Refer to [WCS-5, "WARNING CHIME SYSTEM : System Description"](#) for further details.
The combination meter includes an on board diagnosis function.
The combination meter can be diagnosed with CONSULT.

METER CONTROL FUNCTION LIST

System		Description	Reference
Measuring instruments	Speedometer	Indicates vehicle speed.	MWI-12, "SPEEDOMETER : System Description"
	Tachometer	Indicates engine speed.	MWI-13, "TACHOMETER : System Description"
	Engine coolant temperature gauge	Indicates engine coolant temperature.	MWI-13, "ENGINE COOLANT TEMPERATURE GAUGE : System Description"
	Fuel gauge	Indicates fuel level.	MWI-13, "FUEL GAUGE : System Description"
Information display		The information display displays status according to system malfunction or vehicle condition.	MWI-15, "INFORMATION DISPLAY : System Description"
Meter illumination control	Meter illumination control function	Switches back and forth between daytime mode and nighttime mode according to a light switch position.	MWI-14, "METER ILLUMINATION CONTROL : System Description"
	Back light illumination control function	The operation of the illumination control switch allows the brightness adjustment of meter illumination.	
Meter effect function	Engine-start effect function	Controls pointers of combination meter, back light illumination and information display at engine start to produce illumination effects.	MWI-14, "METER EFFECT FUNCTION : System Description"
	Driver welcome function	Controls meter illumination to produce illumination effects when getting in the vehicle.	

METER SYSTEM : Fail-safe

INFOID:000000012250275

The combination meter activates the fail-safe control if the CAN communication lines between each unit are malfunctioning.

Function	Specifications
Speedometer	Reset to zero by suspending communication.
Tachometer	
Engine coolant temperature gauge	
Meter illumination control	When suspending communication, it changes to nighttime mode.
Buzzer	Turns OFF by suspending communication.

SYSTEM

< SYSTEM DESCRIPTION >

Function		Specifications
Information display	Current fuel consumption	The last result calculated during normal condition is indicated.
	Average fuel consumption	
	Average vehicle speed	
	Range (Distance to empty)	
	Driving distance	
	Door open warning	The display turns OFF by suspending communication.
	Trunk open warning	
	Low tire pressure warning	
	Parking brake release warning	
	Fuel-filler cap warning	
	Oil pressure warning	
	CVT error warning lamp	An indicated value is maintained at communications blackout.
	BSW warning	
	Odo/trip meter	The indicator turns OFF by suspending communication.
Shift selector position indicator		
Warning lamp/indicator lamp	ABS warning lamp	Turns ON by suspending communication.
	Brake warning lamp	
	EPS warning lamp	
	VDC warning lamp	
	FEB warning lamp	
	Malfunction indicator lamp	
	Air bag warning lamp	Turns OFF by suspending communication.
	Charge warning lamp	
	VDC OFF indicator lamp	
	High beam indicator lamp	
	Turn signal indicator lamp	
	Position lamp indicator lamp	
	Front fog lamp indicator lamp	
	Low tire pressure warning lamp	

SPEEDOMETER

SPEEDOMETER : System Description

INFOID:000000012227890

SYSTEM DIAGRAM

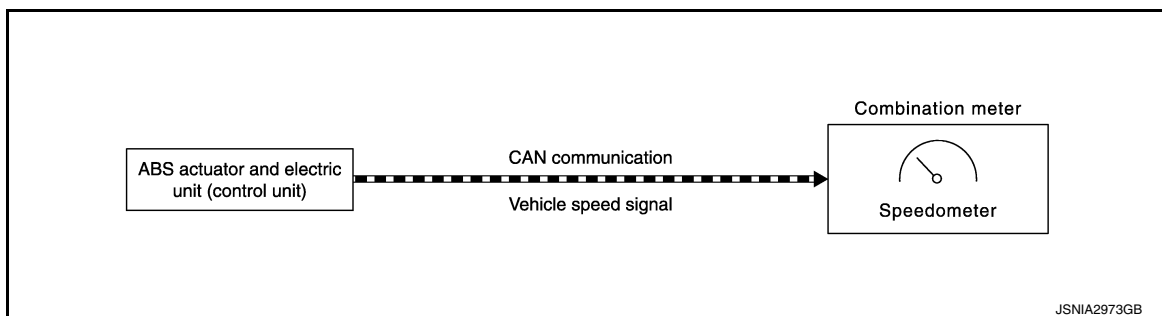

DESCRIPTION

The ABS actuator and electric unit (control unit) receives each wheel speed sensor signal and provides a vehicle speed signal to the combination meter via CAN communication lines.

TACHOMETER

SYSTEM

< SYSTEM DESCRIPTION >

TACHOMETER : System Description

INFOID:000000012227891

SYSTEM DIAGRAM

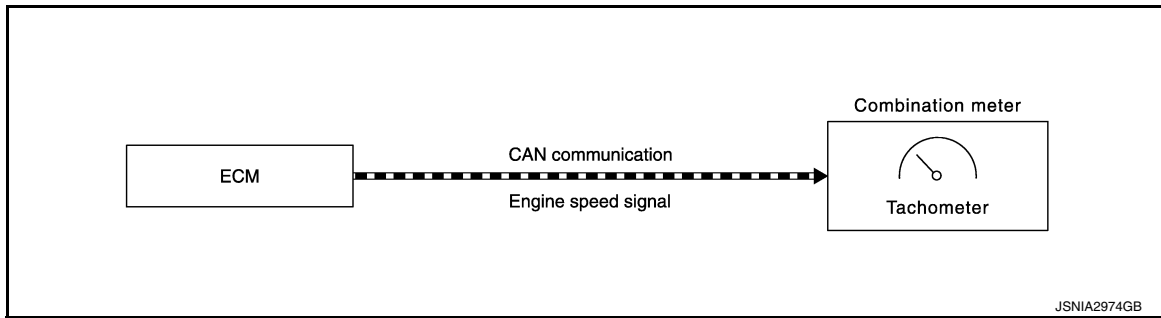

DESCRIPTION

The crank position sensor sends a crankshaft position signal to the ECM. The ECM provides an engine speed signal to the combination meter via CAN communication lines. The tachometer indicates engine speed in revolutions per minute (rpm).

ENGINE COOLANT TEMPERATURE GAUGE

ENGINE COOLANT TEMPERATURE GAUGE : System Description

INFOID:000000012227892

SYSTEM DIAGRAM

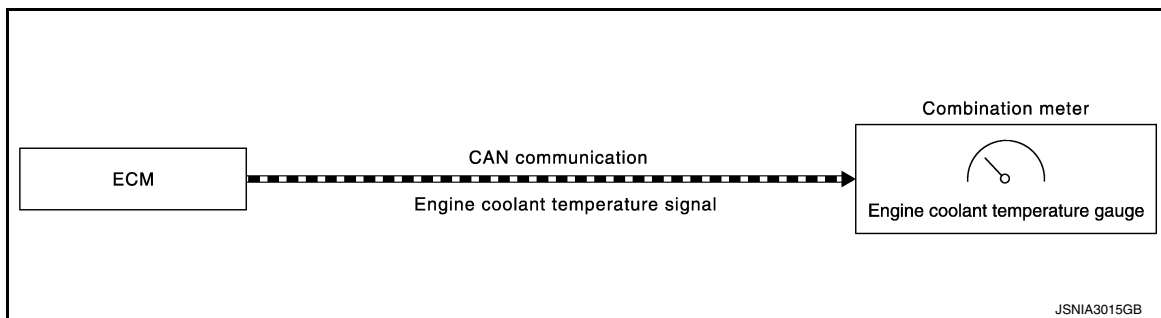

DESCRIPTION

The engine coolant temperature sensor sends an engine coolant temperature signal to the ECM. The ECM provides an engine coolant temperature signal to the combination meter via CAN communication lines. The engine coolant temperature gauge indicates the engine coolant temperature.

FUEL GAUGE

FUEL GAUGE : System Description

INFOID:000000012227893

SYSTEM DIAGRAM

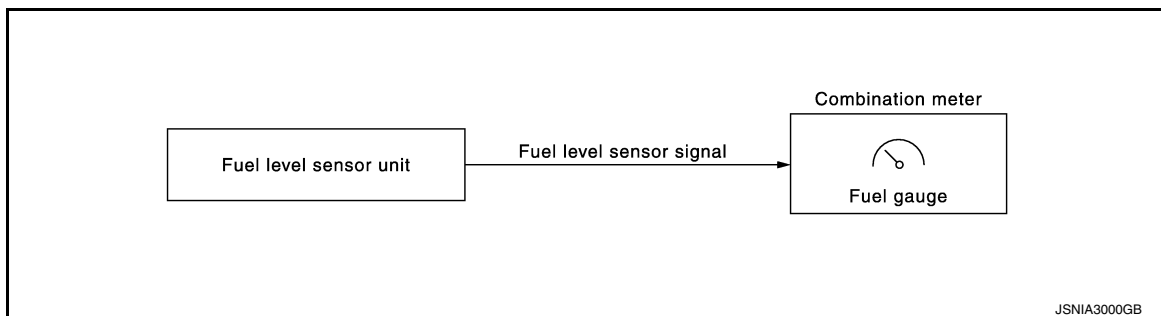

DESCRIPTION

The fuel level sensor unit sends a variable resistor signal to the combination meter. The fuel gauge indicates the approximate fuel level in the fuel tank.

METER ILLUMINATION CONTROL

A
B
C
D
E
F
G
H
I
J
K
L
M
O
P

MWI

SYSTEM

< SYSTEM DESCRIPTION >

METER ILLUMINATION CONTROL : System Description

INFOID:000000012227894

SYSTEM DIAGRAM

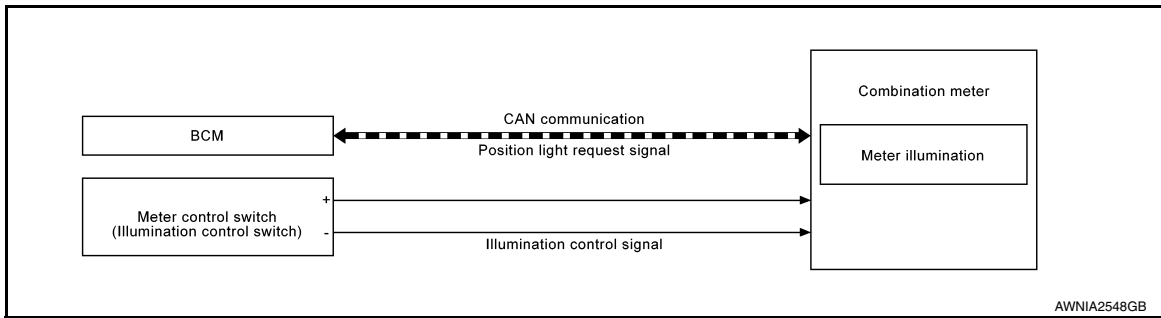

DESCRIPTION

Meter Illumination Control Function

The operation of the illumination control switch changes brightness of the meter illumination.

Meter illumination	The number of adjustable steps
Daytime	21
Nighttime	21

METER EFFECT FUNCTION

METER EFFECT FUNCTION : System Description

INFOID:000000012227895

SYSTEM DIAGRAM

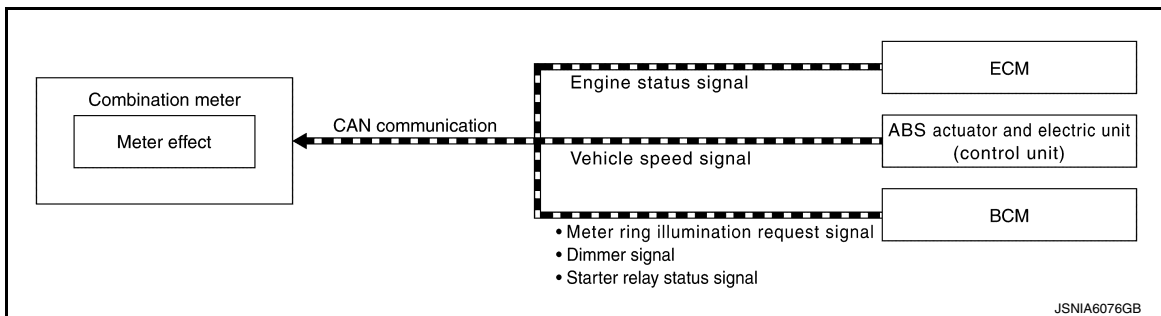

ENGINE-START EFFECT FUNCTION

When recognizing an engine start, the combination meter controls the following items for producing the effect:

- Speedometer
- Tachometer
- Engine coolant temperature gauge
- Fuel gauge
- Meter illumination

Meter and Illumination Operations During Engine-start Effect

The combination meter controls the following items during the engine-start effect:

Control item		Operation
Speedometer		Sweeps the pointer.
Tachometer		Sweeps the pointer.
Engine coolant temperature gauge		Stops the pointer.
Fuel gauge		Stops the pointer.
Meter illumination	Pointers	Turns on the illumination at the effect level.
	Information display	Turns on the illumination at the normal brightness level.
	Other than those above	Increases the brightness to the effect level in stages.

SYSTEM

< SYSTEM DESCRIPTION >

NOTE:

The pointers are stopped and illumination is turned off while cranking the engine.

Engine Start Judgment

The combination meter judges engine-start and activates the engine-start effect only once when the following operational conditions are all satisfied:

Condition	
Ignition switch	ON position
Vehicle speed	Less than 0.6 MPH (1 km/h)
Engine state	Other than the time of cranking the engine
	500 rpm or more
Information display (SETTING)	The setting of "EFFECT" is ON

NOTE:

Engine-start effect exits when any of the above operational conditions are canceled during the engine-start effect.

INFORMATION DISPLAY

INFORMATION DISPLAY : System Description

INFOID:000000012227896

SYSTEM DIAGRAM

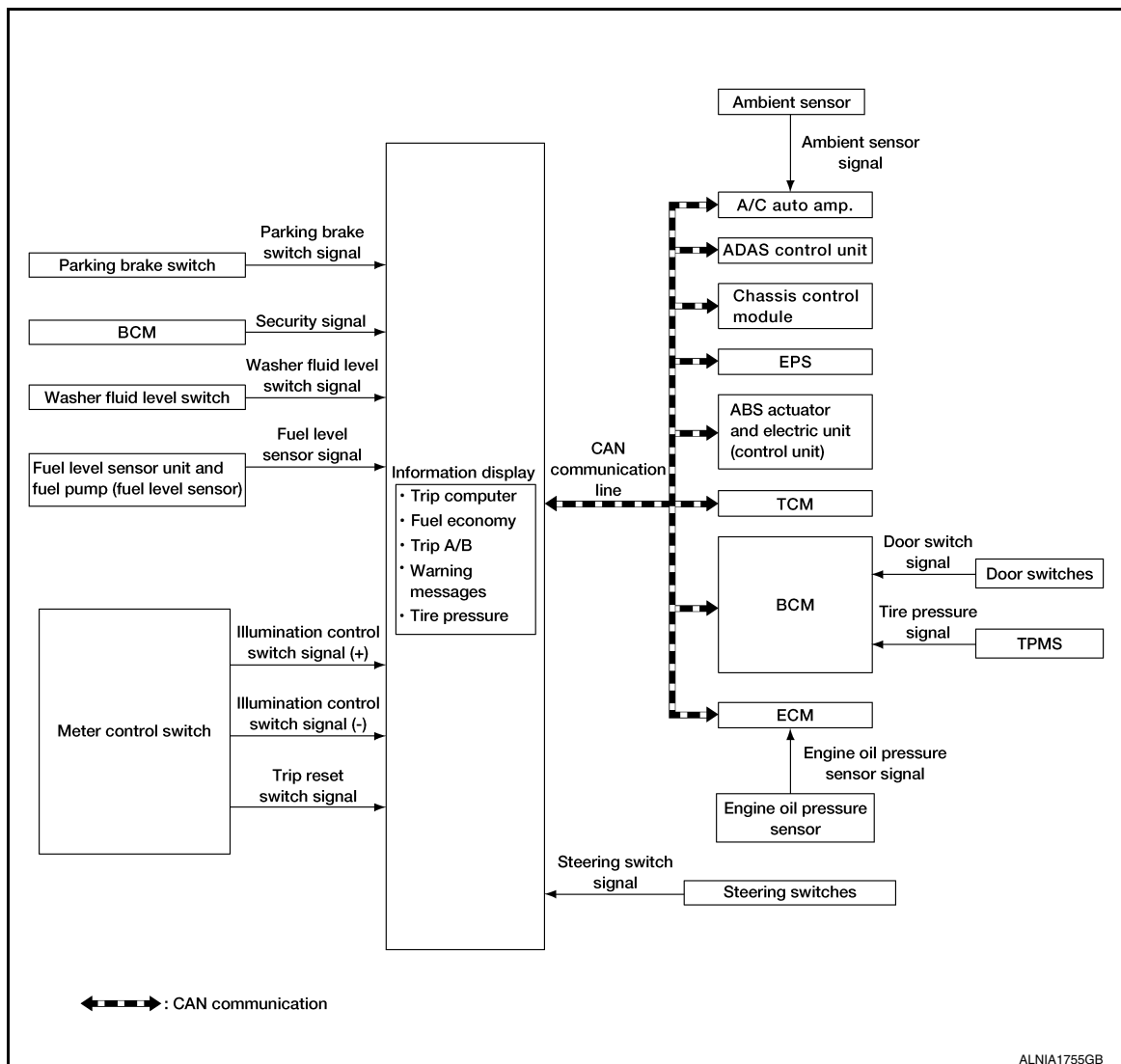

SYSTEM

< SYSTEM DESCRIPTION >

FUNCTION

The information display can indicate the following items:

- Outside air temperature
- Trip computer
- Intelligent Key operation information
- Odometer
- Warning/Indication messages (door open, trunk open, low oil pressure, I-Key, low fuel, low washer fluid, release parking brake, low tire pressure and loose fuel cap).

OUTSIDE AIR TEMPERATURE INDICATION

This indication displays the ambient temperature based on signal received from the A/C auto amp. via CAN communication lines.

LOOSE FUEL CAP MESSAGE

The LOOSE FUEL CAP message will display in the information display when the fuel-filler cap is not tightened correctly. The message will turn off as soon as the ECM detects the fuel-filler cap is properly tightened. The ECM provides a loose fuel cap signal to the combination meter via CAN communication lines.

LOW TIRE PRESSURE WARNING

This warning appears when the BCM detects low inflation pressure or a system malfunction. The BCM sends a signal to the combination meter via CAN communication lines to illuminate the low tire pressure warning lamp. In addition, a warning message will be displayed in the vehicle information display.

DOOR OPEN WARNING

This warning appears when the ignition switch is ON and the door is open. The BCM receives a door switch signal from the door switch of the open door. The BCM sends the door switch signal to the combination meter via CAN communication lines.

TRUNK OPEN WARNING

This warning appears when the ignition switch is ON and the trunk is opened. The BCM receives a trunk open switch signal from the trunk lamp switch. The BCM sends the trunk lamp switch signal to the combination meter via CAN communication lines.

LOW FUEL WARNING

This warning appears when the fuel level in the fuel tank is low.

LOW WINDSHIELD WASHER FLUID WARNING

When the windshield washer fluid level is low, the washer fluid level switch provides a ground signal to the combination meter and the warning is displayed. Once fluid is added, the switch opens and the warning is no longer displayed.

RELEASE PARKING BRAKE WARNING

When the parking brake is applied, the parking brake switch provides a ground signal to the combination meter. When the vehicle speed is greater than 4 MPH (7 km/h), the message is displayed and the warning chime sounds.

LOW OIL PRESSURE WARNING

The low oil pressure warning appears in the information display when the combination meter receives a low engine oil pressure signal from the ECM via CAN communication lines.

WARNING CHECK INDICATION

The combination meter can cause an interruption on the information display to indicate a warning, based on signals received from each unit and switch.

Refer to Owner's Manual for additional information on the information display items.

OPERATION

< SYSTEM DESCRIPTION >

OPERATION

Switch Name and Function

INFOID:000000012227897

STEERING SWITCHES

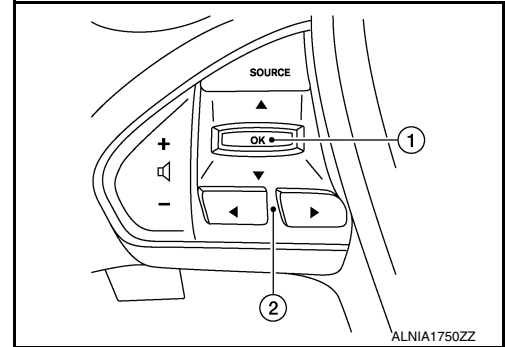

No.	Switch name	Operation	Description
1.	Enter/Up/Down switch	Press	The information display settings can be changed.
2.	Back or forward switch		

METER CONTROL SWITCH

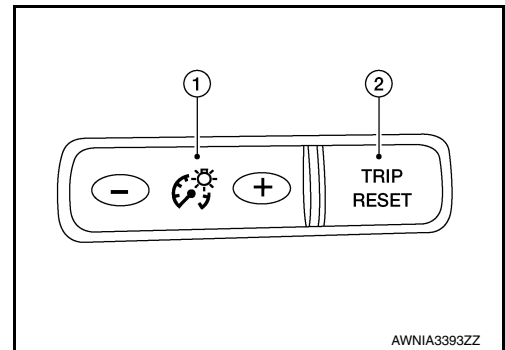

No.	Switch name	Operation	Description
1.	Illumination control switch	Press	The illumination level of the back light of the combination meter can be adjusted.
2.	Trip reset switch	Press	<ul style="list-style-type: none"> The trip meter can be switched between A and B. Trip meter A/B can be reset by pressing and holding the trip reset switch. A trip computer value displayed on the information display can be reset by pressing and holding the trip reset switch for 1 second or more. All trip computer values can be reset by pressing and holding the trip reset switch for 3 seconds or more.

A
B
C
D
E
F
G
H
I
J
K
L
M
MWI
O
P

DIAGNOSIS SYSTEM (COMBINATION METER)

< SYSTEM DESCRIPTION >

DIAGNOSIS SYSTEM (COMBINATION METER)

On Board Diagnosis Function

INFOID:000000012227898

COMBINATION METER SELF-DIAGNOSIS MODE

The following meter functions can be checked during Combination Meter Self-Diagnosis Mode:

- Pointer sweep of speedometer, tachometer and gauges
- Illumination of all LCD segments and color patterns for meter displays
- Illumination of all lamps/LEDs that are controlled by the combination meter (regardless of switch status)

STARTING COMBINATION METER SELF-DIAGNOSIS MODE

NOTE:

- Check combination meter power supply and ground circuits if self-diagnosis mode does not start. Refer to [MWI-50, "COMBINATION METER : Diagnosis Procedure"](#). Replace combination meter if power supply and ground circuits are found to be normal and self-diagnosis mode does not start. Refer to [MWI-68, "Removal and Installation"](#).
- Combination meter self-diagnosis mode will function with the ignition switch in ON. Combination meter self-diagnosis mode will exit upon turning the ignition switch to OFF.

How to Initiate Self-Diagnosis Mode

1. Turn ignition switch OFF.
2. While pressing the trip reset switch (1), turn ignition switch ON.
3. Keep pressing the trip reset switch for 1 second or more.
4. Press the trip reset switch at least 3 times within 7 seconds after the ignition switch is turned ON.
5. "Work instruction code" is indicated in the top portion of information display and self-diagnosis is started.
6. The mode switches in the order shown below each time the trip reset switch is pressed.

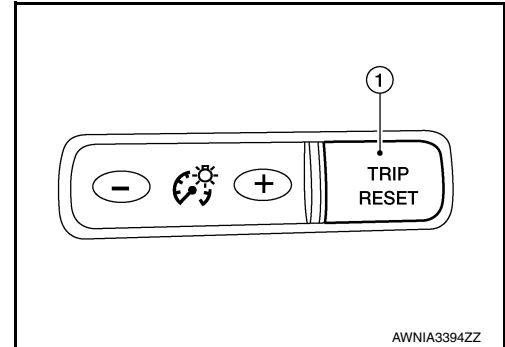

NOTE:

If the trip reset switch is not operated for 20 seconds or more, the self-diagnosis mode is automatically canceled.

AWNIA3394ZZ

Test order	Test item	Description
1	Work instruction code	This item is displayed, but not used.
2	Part number	
3	Software code	
4	EEPROM code	
5	Hardware code	
6	P.C.B code	
7	Circuit check	<p>The pointer of the following items moves from 0 to MAX twice:</p> <ul style="list-style-type: none"> • Speedometer • Tachometer • Engine coolant temperature gauge • Fuel gauge <p>NOTE: If any of the pointers does not sweep, replace combination meter.</p>
8	Color check	Performs the color check of the information display.
9	Error code	<p>Displays the error code of the following items:</p> <ul style="list-style-type: none"> • Speedometer • Tachometer • Engine coolant temperature gauge • Fuel gauge • Meter control switch
10	Warning/indicator lamp check	All warning/indicator lamps illuminate.

DIAGNOSIS SYSTEM (COMBINATION METER)

< SYSTEM DESCRIPTION >

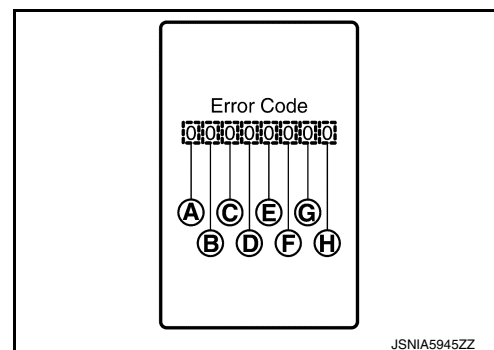

Item	Code	Description	Action to take/Reference
Ⓐ Speedometer	0	Normal	—
	1	A vehicle speed signal cannot be received from ABS actuator and electric unit (control unit).	Perform "Self Diagnostic Result" of "ABS." Refer to MWI-29, "DTC Index" .
	2	A vehicle speed signal received from the ABS actuator and electric unit (control unit) is abnormal.	
Ⓑ Tachometer	0	Normal	—
	1	An engine speed signal cannot be received from ECM.	Perform "Self Diagnostic Result" of "ECM." Refer to MWI-29, "DTC Index" .
Ⓒ Fuel gauge	0	Normal	—
	1	Fuel gauge circuit is shorted.	Refer to MWI-54, "Component Function Check" .
	2	Fuel gauge circuit is open.	
Ⓓ Engine coolant temperature gauge	0	Normal	—
	1	An engine coolant temperature signal cannot be received from ECM.	Perform "Self Diagnostic Result" of "ECM." Refer to MWI-29, "DTC Index" .
Ⓔ Meter control switch	0	Normal	—
	1	When judging that the illumination control switch signal circuit is shorted for 5 minutes or more.	Refer to MWI-52, "Diagnosis Procedure" .
	2	When judging that the trip reset switch signal circuit is shorted for 5 minutes or more.	
	3	When judging that both switch signal circuit are shorted for 5 minutes or more.	
Ⓕ —	0	Displays "0" constantly.	—
Ⓖ —	0	Displays "0" constantly.	—
Ⓗ —	0	Displays "0" constantly.	—

How to Reset Error Code

Error codes stored in combination meter can be reset by following the instructions below:

1. Turn ignition switch OFF.
2. While pressing the trip reset switch, turn ignition switch ON.
3. Keep pressing the trip reset switch for 1 second or more.
4. Press the trip reset switch at least 3 times within 7 seconds after the ignition switch is turned ON.
5. Turn ignition switch OFF.
6. Perform self-diagnosis and check that the error codes are reset.

DIAGNOSIS SYSTEM (COMBINATION METER)

< SYSTEM DESCRIPTION >

CONSULT Function (METER/M&A)

INFOID:000000012227899

APPLICATION ITEMS

CONSULT can display each diagnostic item using the diagnostic test modes shown.

METER/M&A Diagnosis mode	Description
Self Diagnostic Result	Displays combination meter self-diagnosis results.
Data Monitor	Displays combination meter input/output data in real time.
Work support	Displays diagnosis procedure of each work item.
Warning History	Lighting history of the warning lamp and indicator lamp can be checked.
CAN DIAG SUPPORT MNTR	The result of transmit/receive diagnosis of CAN communication can be read.

SELF DIAG RESULT

Refer to [MWI-29, "DTC Index"](#).

DATA MONITOR

Display Item List

X: Applicable

Display item [Unit]	MAIN SIGNALS	Description
SPEED METER	X	Displays the value of vehicle speed signal.
SPEED OUTPUT [mph or km/h]	X	Vehicle speed signal value transmitted to other units via CAN communication.
ODO OUTPUT [mph or km/h]		Odometer signal value transmitted to other units via CAN communication.
TACHO METER [rpm]	X	Value of the engine speed signal received from ECM via CAN communication.
FUEL METER [L]	X	Fuel level indicated on combination meter.
W TEMP METER [°F] or [°C]	X	Displays the value of engine coolant temperature signal, which is input from ECM.
ABS W/L [On/Off]		Displays [ON/OFF] condition of ABS warning indicator.
VDC/TCS IND [On/Off]		Displays [ON/OFF] condition of VDC OFF indicator lamp.
SLIP IND [On/Off]		Displays [ON/OFF] condition of SLIP indicator lamp.
BRAKE W/L [On/Off]		Displays [ON/OFF] condition of brake warning indicator.
DOOR W/L [On/Off]		Displays [ON/OFF] condition of door warning message in the information display.
TRUNK/GLAS-H [On/Off]		Displays [ON/OFF] condition of trunk warning message in the information display.
HI-BEAM IND [On/Off]		Displays [ON/OFF] condition of high beam indicator.
TURN IND [On/Off]		Displays [ON/OFF] condition of turn indicator.
LIGHT IND [On/Off]		Displays [ON/OFF] condition of light indicator.
FR FOG IND [On/Off]		Displays [ON/OFF] condition of front fog lamp indicator.
OIL W/L [On/Off]		Displays [ON/OFF] condition of low oil pressure warning message in the information display.

DIAGNOSIS SYSTEM (COMBINATION METER)

< SYSTEM DESCRIPTION >

Display item [Unit]	MAIN SIGNALS	Description	
MIL [On/Off]		Displays [ON/OFF] condition of malfunction indicator.	A
BA W/L [On/Off]		Displays [ON/OFF] condition of FEB warning lamp indicator.	B
ATC/T-AMT W/L [On/Off]		Displays [ON/OFF] condition of CVT error warning message in the information display.	C
SPORT IND [On/Off]		Displays [ON/OFF] condition of SPORT indicator in the information display.	
FUEL W/L [On/Off]		Displays [ON/OFF] condition of low-fuel warning message in the information display.	D
WASHER W/L [On/Off]		Displays [ON/OFF] condition of low washer fluid warning message in the information display.	E
AIR PRES W/L [On/Off]		Displays [ON/OFF] condition of tire pressure warning lamp.	
KEY G/Y W/L [On/Off]		Displays [ON/OFF] condition of key green warning lamp.	F
EPS W/L [On/Off]		Displays [ON/OFF] condition of EPS warning indicator.	G
LCD		Displays the value of Intelligent Key system message indication.	
ACC TARGET [On/Off]		Displays [ON/OFF] condition of vehicle ahead detection indicator in the information display.	H
ACC DISTANCE [Off, Short, Middle, Long]		Displays [Off, Short, Middle, Long] condition of set distance indicator in the information display.	
SHIFT IND [P, R, N, D]		Displays shift selector position.	I
FUEL CAP W/L [On/Off]		Displays [ON/OFF] condition of loose fuel cap warning message in the information display.	J
PKB SW [On/Off]		Displays [ON/OFF] condition of parking brake switch.	
BUCKLE SW [On/Off]		Displays [ON/OFF] condition of seat belt buckle switch LH.	K
BRAKE OIL SW [On/Off]		Displays [ON/OFF] condition of brake fluid level switch.	L
DISTANCE [Mi] or [km]		Displays distance to empty.	
OUTSIDE TEMP [°F or °C]		Displays the ambient air temperature which is input from the ambient sensor.	M
FUEL LOW SIG [On/Off]		Displays [ON/OFF] condition of low-fuel warning signal.	
BUZZER [On/Off]	X	Buzzer status (in the combination meter) is detected from the buzzer output signal received from each unit via CAN communication and the warning output condition of the combination meter.	MWI
BATTERY CIRCUIT STATUS [Normal/Open]		Displays [Normal/Open] condition of battery power supply circuit.	O
TPMS PRESS L [On/Off]		Displays [ON/OFF] condition of tire pressure low message in the information display.	P
BSW IND [On/Off]		Displays [ON/OFF] condition of blind spot warning indicator.	
CHASSIS CONTROL WARN [On/Off]		Displays [ON/OFF] condition of chassis control system error warning message in the information display.	

WORK SUPPORT

DIAGNOSIS SYSTEM (COMBINATION METER)

< SYSTEM DESCRIPTION >

Work support item	Description
Outside air temperature diagnosis	A possible malfunction can be narrowed down by following the displayed instructions.
Fuel meter diagnosis (Analog pointer)	
Warning/Indicator lamp diagnosis	

WARNING HISTORY

Special menu

Display item	Description
W/L ON HISTORY	Lighting history of warning lamp and indicator lamp can be checked.

W/L ON HISTORY

- “W/L ON HISTORY” indicates the “TIME” when the warning/indicator lamp is turned on.
- The “TIME” above is:
 - 0: The condition that the warning/indicator lamp has been turned on 1 or more times after starting the engine and waiting for 30 seconds.
 - 1 - 39: The number of times the engine was restarted after the 0 condition.
 - NO W/L ON HISTORY: No warning/indicator lamp history is stored.

NOTE:

- “W/L ON HISTORY” is not stored for approximately 30 seconds after the engine starts.
- Brake warning lamp does not store any history when the parking brake is applied or the brake fluid level gets low.

COMBINATION METER

< ECU DIAGNOSIS INFORMATION >

ECU DIAGNOSIS INFORMATION

COMBINATION METER

Reference Value

INFOID:0000000012227900

VALUES ON THE DIAGNOSIS TOOL

Monitor Item	Condition		Value/Status
SPEED METER [mph or km/h]	Ignition switch ON	While driving.	Input value of vehicle speed signal (CAN communication signal).
SPEED OUTPUT [mph or km/h]	Ignition switch ON	While driving.	Output value of vehicle speed signal (CAN communication signal).
ODO OUTPUT [mph or km/h]	Ignition switch ON	—	Output value of odometer signal (CAN communication signal).
TACHO METER [rpm]	Ignition switch ON	Engine running.	Input value of engine speed signal (CAN communication signal).
FUEL METER [L]	Ignition switch ON	—	Input value of fuel level sensor signal.
W TEMP METER [°F] or [°C]	Ignition switch ON	—	Input value of engine coolant temperature signal (CAN communication signal).
ABS W/L	Ignition switch ON	ABS warning lamp ON.	On
		ABS warning lamp OFF.	Off
VDC/TCS IND	Ignition switch ON	VDC OFF indicator lamp ON.	On
		VDC OFF indicator lamp OFF.	Off
SLIP IND	Ignition switch ON	VDC warning lamp ON.	On
		VDC warning lamp OFF.	Off
BRAKE W/L	Ignition switch ON	Brake warning lamp ON.	On*1
		Brake warning lamp OFF.	Off
DOOR W/L	Ignition switch ON	Door open warning displayed.	On
		Other than the above	Off
TRUNK/GLAS-H	Ignition switch ON	Trunk open warning displayed.	On
		Other than the above	Off
HI-BEAM IND	Ignition switch ON	High beam indicator lamp ON.	On
		High beam indicator lamp OFF.	Off
TURN IND	Ignition switch ON	Turn signal indicator lamp ON.	On
		Turn signal indicator lamp OFF.	Off
FR FOG IND	Ignition switch ON	Front fog lamp indicator lamp ON.	On
		Front fog lamp indicator lamp OFF.	Off
LIGHT IND	Ignition switch ON	Position lamp indicator lamp ON.	On
		Position lamp indicator lamp OFF.	Off
OIL W/L	Ignition switch ON	Engine oil pressure warning displayed.	On
		Other than the above.	Off
MIL	Ignition switch ON	Malfunction indicator lamp ON.	On
		Malfunction indicator lamp OFF.	Off
BA W/L	Ignition switch ON	FEB warning lamp ON	On
		FEB warning lamp OFF	Off
ATC/T-AMT W/L	Ignition switch ON	CVT error warning is displayed	On
		Other than the above	Off

COMBINATION METER

< ECU DIAGNOSIS INFORMATION >

Monitor Item	Condition		Value/Status
SPORT IND	Ignition switch ON	SPORT indicator displayed.	On
		Other than the above.	Off
FUEL W/L	Ignition switch ON	Low fuel warning displayed.	On
		Low fuel warning lamp OFF.	Off
WASHER W/L	Ignition switch ON	Low washer fluid warning displayed.	On
		Other than the above.	Off
AIR PRES W/L	Ignition switch ON	Low tire pressure warning lamp ON.	On
		Low tire pressure warning lamp OFF.	Off
KEY G/Y W/L	Ignition switch ON	Intelligent Key system warning indication.	On
		Other than the above.	Off
EPS W/L	Ignition switch ON	Power steering warning lamp ON.	On
		Power steering warning lamp OFF.	Off
ACC TARGET	Ignition switch ON	During vehicle ahead detection indication.	On
		Other than the above	Off
ACC DISTANCE	Ignition switch ON	When following distance is set to "LONG"	LONG
		When following distance is set to "MID-DLE"	MID
		When following distance is set to "SHORT"	SHORT
		Set distance indicator not displayed	Off
SHIFT IND	Ignition switch ON	Shift selector position indicator displayed.	[P, R, N, D, L]
FUEL CAP W/L	Ignition switch ON	Fuel filler cap warning displayed.	On
		Other than the above.	Off
PKB SW	Ignition switch ON	Parking brake switch ON.	On
		Parking brake switch OFF.	Off
BUCKLE SW	Ignition switch ON	Driver seat belt not fastened.	On
		Driver seat belt fastened.	Off
BRAKE OIL SW	Ignition switch ON	Brake fluid level switch ON.	On
		Brake fluid level switch OFF.	Off
DISTANCE [mi] or [km]	Ignition switch ON	—	Distance to empty.
OUTSIDE TEMP [°F] or [°C]	Ignition switch ON	—	Displays the ambient air temperature which is input from the ambient sensor.
FUEL LOW SIG	—	Low fuel level warning.	On
		Except during low fuel level warning.	Off
BUZZER	Ignition switch ON	Buzzer ON.	On
		Buzzer OFF.	Off
BATTERY CIRCUIT STATUS	Ignition switch ON	Battery power supply circuit is normal	Normal
		Battery power supply circuit is open	Open
LCD	Ignition switch ON	Engine start information.	B&P
TPMS PRESS L	Ignition switch ON	Tire pressure is low.	On
		Tire pressure is normal.	Off
BSW IND	Ignition switch ON	Blind spot warning indicator ON.	On
		Blind spot warning indicator OFF.	Off
CHASSIS CONTROL WARN	Ignition switch ON	Chassis control warning is displayed.	On
		Other than the above.	Off

COMBINATION METER

< ECU DIAGNOSIS INFORMATION >

*1: Displays "Off" if the brake warning lamp is illuminated when the valve check starts, the parking brake switch is turned ON or the brake fluid level switch is turned ON.

TERMINAL LAYOUT

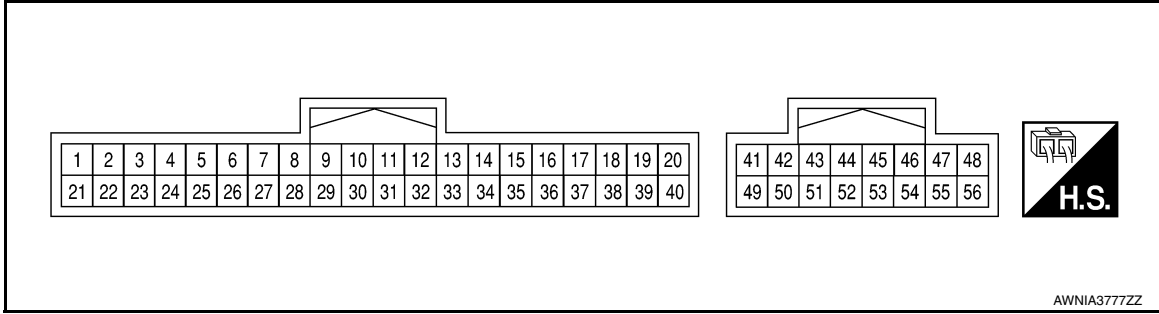

PHYSICAL VALUES

Terminal No. (Wire color)		Description		Condition		Value (Approx.)
+	-	Signal name	Input/ Output			
7 (G)	Ground	Security signal	Input	Ignition switch OFF	Security indicator ON	0 V
					Security indicator OFF	Battery voltage
10 (GR)	Ground	Ground	—	—	—	0 V
11 (R)	Ground	Generator signal	—	Ignition switch ON	Charge warning lamp ON	2 V
					Charge warning lamp OFF	Battery voltage
12 (BG)	Ground	LED headlamp RH warning signal	Input	Ignition switch ON	Headlamp ON	1.0 V
					Headlamp OFF	Battery voltage
13 (W)	Ground	LED headlamp LH warning signal	Input	Ignition switch ON	Headlamp ON	1.0 V
					Headlamp OFF	Battery voltage
14 (P)	Ground	ACC power supply	—	Ignition switch ACC	—	Battery voltage
17 (G)	Ground	Meter control switch ground	—	—	—	0 V
18 (V)	Ground	Trip/reset switch signal	Input	Ignition switch OFF or ON	Trip/Reset switch is pressed	0 V
					Other than the above	5.0 V
21 (W)	Ground	Steering switch ground	—	—	—	0 V
22 (P)	Ground	Steering switch input 1	—	—	—	—
23 (G)	Ground	Steering switch input 2	—	—	—	—
24 (BG)	Ground	Washer fluid level switch signal	Input	Ignition switch ON	Washer fluid level switch ON	0 V
					Washer fluid level switch OFF	Battery voltage
25 (BR)	Ground	Brake fluid level switch signal	Input	Ignition switch ON	Brake fluid level low	0 V
					Brake fluid level normal	Battery voltage

COMBINATION METER

< ECU DIAGNOSIS INFORMATION >

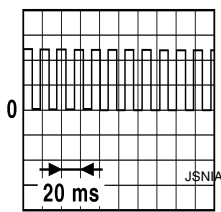
Terminal No. (Wire color)		Description		Condition		Value (Approx.)
+	-	Signal name	Input/ Output			
26 (V)	Ground	Parking brake switch signal	Input	Ignition switch ON	Parking brake applied	0 V
					Parking brake released	Battery voltage
28 (LG)	Ground	Seat belt buckle switch signal LH	Input	Ignition switch ON	When driver seat belt is fastened	Battery voltage
					When driver seat belt is unfastened	0 V
30 (W)	Ground	Manual mode signal	Input	Ignition switch ON	Selector lever manual mode position	0 V
					Other than the above	Battery voltage
31 (G)	Ground	Non-manual mode signal	Input	Ignition switch ON	Selector lever manual mode position	Battery voltage
					Other than the above	0 V
32 (P)	Ground	Manual mode shift up signal	Input	Ignition switch ON	Shift selector UP operation	0 V
					Other than the above	Battery voltage
33 (BG)	Ground	Manual mode shift down signal	Input	Ignition switch ON	Shift selector DOWN operation	0 V
					Other than the above	Battery voltage
34 (R)	Ground	Paddle shift up signal	Input	Ignition switch ON	Paddle shift UP operation	0 V
					Other than the above	Battery voltage
35 (W)	Ground	Paddle shift down signal	Input	Ignition switch ON	Paddle shift DOWN operation	0 V
					Other than the above	Battery voltage
36 (Y)	Ground	Illumination control switch signal (+)	Input	Ignition switch OFF or ON	When illumination control switch (+) is pressed	0 V
					Other than the above	5.0 V
37 (SB)	Ground	Illumination control switch signal (-)	Input	Ignition switch OFF or ON	When illumination control switch (-) is pressed	0 V
					Other than the above	5.0 V
38 (BG)	Ground	Vehicle speed signal (8-pulse)	Output	Ignition switch ON	Speedometer operated [When vehicle speed is approx. 25 MPH (40 km/h)]	<p>NOTE: The maximum voltage varies depending on the specification (destination unit).</p> 

COMBINATION METER

< ECU DIAGNOSIS INFORMATION >

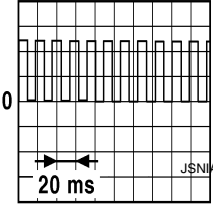
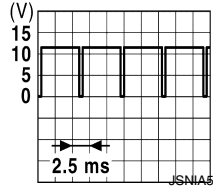
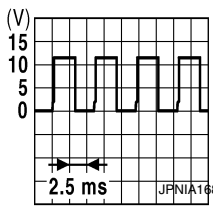
Terminal No. (Wire color)		Description		Condition	Value (Approx.)
+	-	Signal name	Input/ Output		
39 (P)	Ground	Vehicle speed signal (2-pulse)	Output	Ignition switch ON Speedometer operated [When vehicle speed is approx. 25 MPH (40 km/h)]	<p>NOTE: The maximum voltage varies depending on the specification (destination unit).</p> 
42 (GR)	Ground	Illumination control signal	Output	Ignition switch ON	<ul style="list-style-type: none"> Lighting switch 1st position When meter illumination is minimum 
					<ul style="list-style-type: none"> Lighting switch 1st position When meter illumination is step 11 
					<ul style="list-style-type: none"> Lighting switch 1st position When meter illumination is maximum <p style="text-align: center;">0 V</p>
43 (B)	Ground	Ground	—	—	0 V
44 (BR)	Ground	Ignition signal	—	Ignition switch ON or START	Battery voltage
45 (B)	Ground	Ground	—	—	0 V
46 (G)	Ground	Battery power supply	—	—	Battery voltage
47 (BG)	Ground	Welcome lighting illumination control	—	—	—
48 (R)	Ground	Fuel level sensor signal	—	Ignition switch ON	Battery voltage
49 (LG)	Ground	M CAN low	—	—	—
50 (SB)	Ground	M CAN high	—	—	—

A
B
C
D
E
F
G
H
I
J
K
L
M
O
P

MWI

COMBINATION METER

< ECU DIAGNOSIS INFORMATION >

Terminal No. (Wire color)		Description		Condition		Value (Approx.)
+	-	Signal name	Input/ Output			
52 (P)	Ground	CAN low	—	—	—	—
53 (L)	Ground	CAN high	—	—	—	—
54 (W)	Ground	Fuel level sensor ground	—	Ignition switch ON	—	0 V

Fail-safe

INFOID:000000012227901

The combination meter activates the fail-safe control if the CAN communication lines between each unit are malfunctioning.

Function		Specifications
Speedometer		Reset to zero by suspending communication.
Tachometer		
Engine coolant temperature gauge		
Meter illumination control		When suspending communication, it changes to nighttime mode.
Buzzer		Turns OFF by suspending communication.
Information display	Current fuel consumption	The last result calculated during normal condition is indicated.
	Average fuel consumption	
	Average vehicle speed	
	Range (Distance to empty)	
	Driving distance	
	Door open warning	The display turns OFF by suspending communication.
	Trunk open warning	
	Low tire pressure warning	
	Parking brake release warning	
	Fuel-filler cap warning	
	Oil pressure warning	
	CVT error warning lamp	An indicated value is maintained at communications blackout.
	BSW warning	
Odo/trip meter	The indicator turns OFF by suspending communication.	
Shift selector position indicator		

COMBINATION METER

< ECU DIAGNOSIS INFORMATION >

Function		Specifications	
Warning lamp/indicator lamp	ABS warning lamp	Turns ON by suspending communication.	A
	Brake warning lamp		B
	EPS warning lamp		C
	VDC warning lamp		D
	FEB warning lamp		E
	Malfunction indicator lamp		F
	Air bag warning lamp		
	Charge warning lamp	Turns OFF by suspending communication.	G
	VDC OFF indicator lamp		H
	High beam indicator lamp		I
	Turn signal indicator lamp		J
	Position lamp indicator lamp		K
	Front fog lamp indicator lamp		L
	Low tire pressure warning lamp		After blinking for 1 minute, the lamp remains ON.

DTC Index

INFOID:000000012227902

Display contents of CONSULT	Diagnostic item is detected when...	Refer to	
CAN COMM CIRCUIT [U1000]	Combination meter is not transmitting or receiving CAN communication signal for 2 seconds or more.	MWI-45	H
CONTROL UNIT (CAN) [U1010]	Detecting error during the initial diagnosis of CAN controller of combination meter.	MWI-46	I
VEHICLE SPEED [B2205]	The abnormal vehicle speed signal is input from ABS actuator and electric unit (control unit) for 2 seconds or more.	MWI-47	J
ENGINE SPEED [B2267]	ECM continuously transmits abnormal engine speed signals for 2 seconds or more.	MWI-48	K
WATER TEMP [B2268]	ECM continuously transmits abnormal engine coolant temperature signals for 60 seconds or more.	MWI-49	L

MWI

BCM (BODY CONTROL MODULE)

< ECU DIAGNOSIS INFORMATION >

BCM (BODY CONTROL MODULE)

List of ECU Reference

INFOID:000000012227903

ECU	Reference
BCM	BCS-31. "Reference Value"
	BCS-51. "Fail Safe"
	BCS-52. "DTC Inspection Priority Chart"
	BCS-53. "DTC Index"

METER SYSTEM

< WIRING DIAGRAM >

WIRING DIAGRAM

METER SYSTEM

Wiring Diagram

INFOID:000000012227904

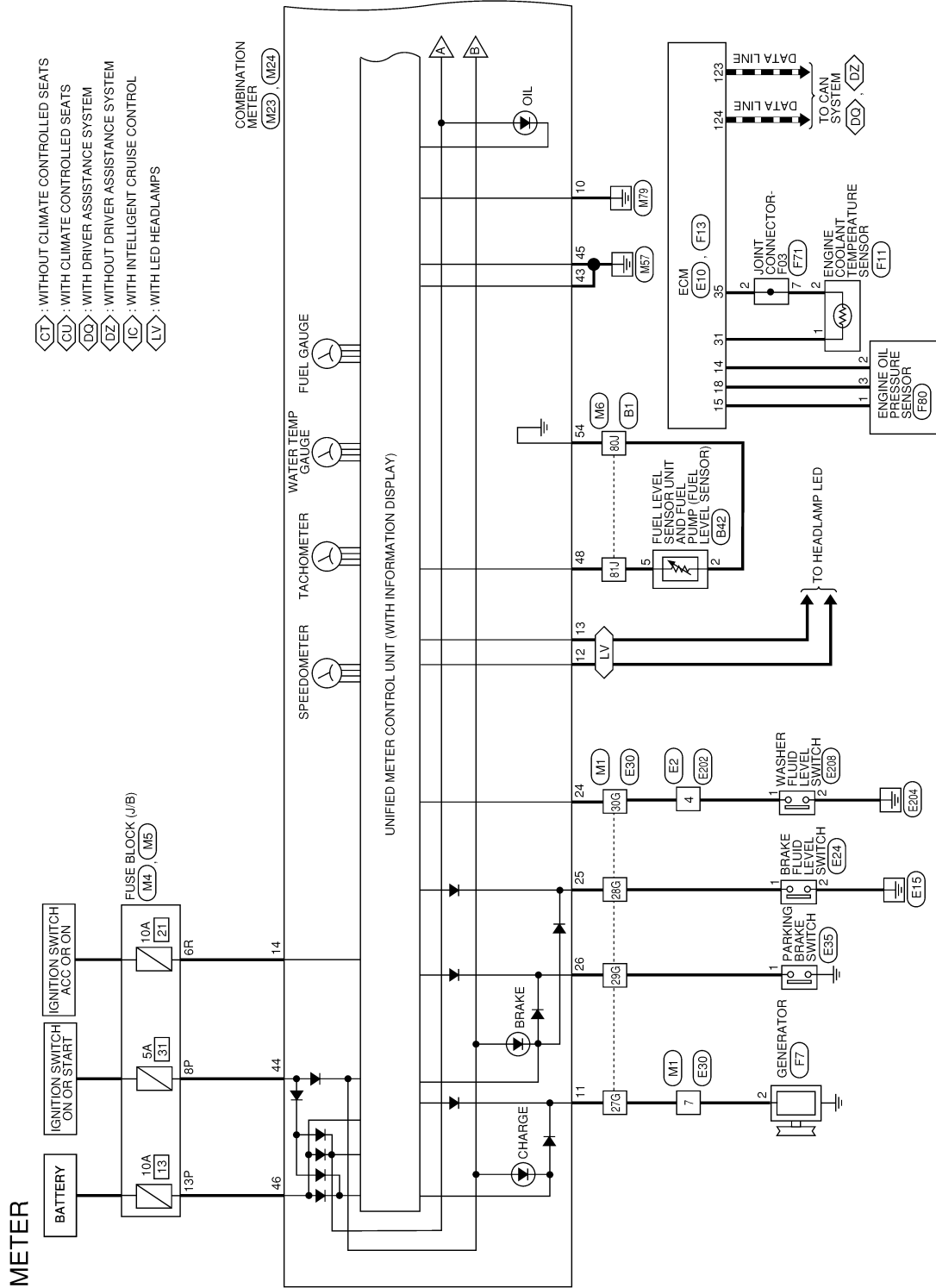

* : THIS CONNECTOR IS NOT SHOWN IN "HARNES LAYOUT" OF PG SECTION.

AANWA1388GB

A
B
C
D
E
F
G
H
I
J
K
L
M
N
O
P



METER SYSTEM

< WIRING DIAGRAM >

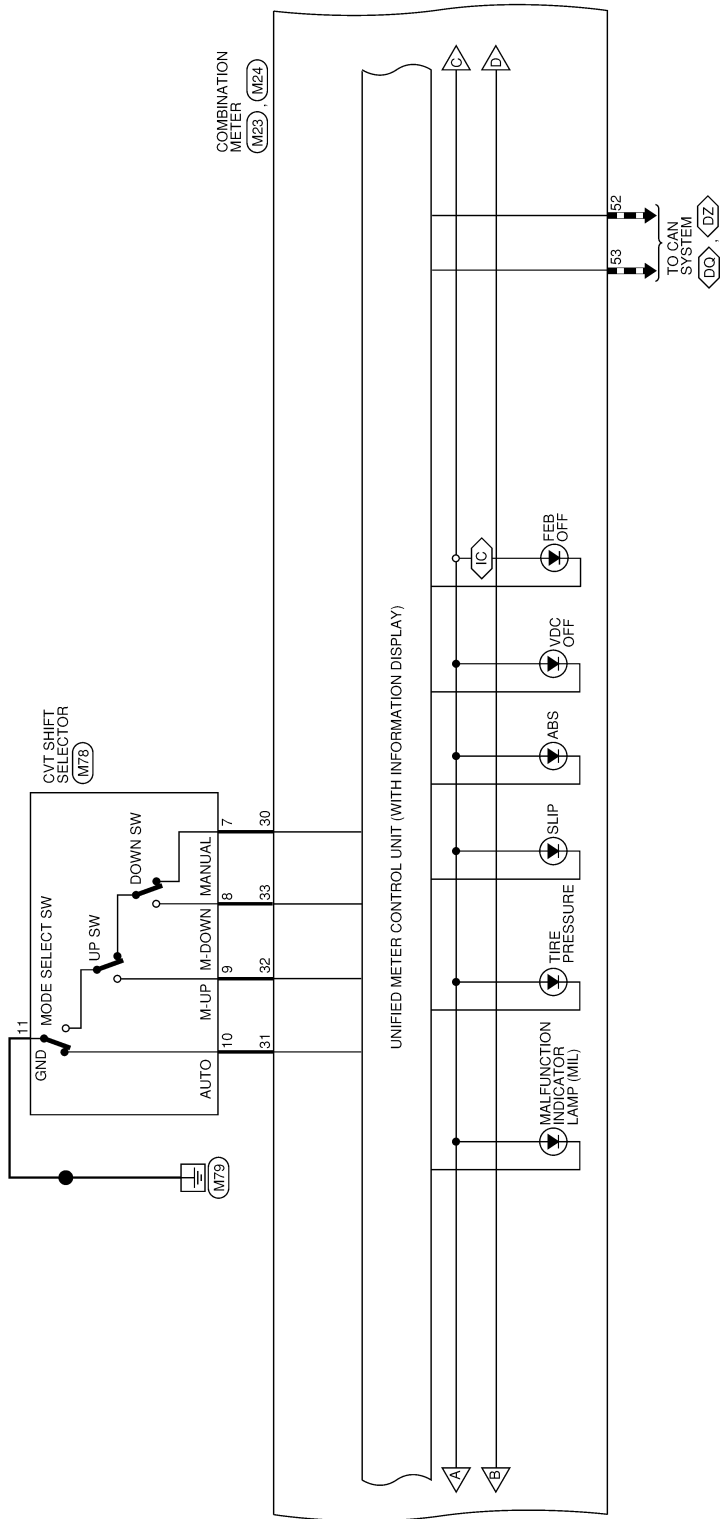

AANWA1389GB

METER SYSTEM

< WIRING DIAGRAM >

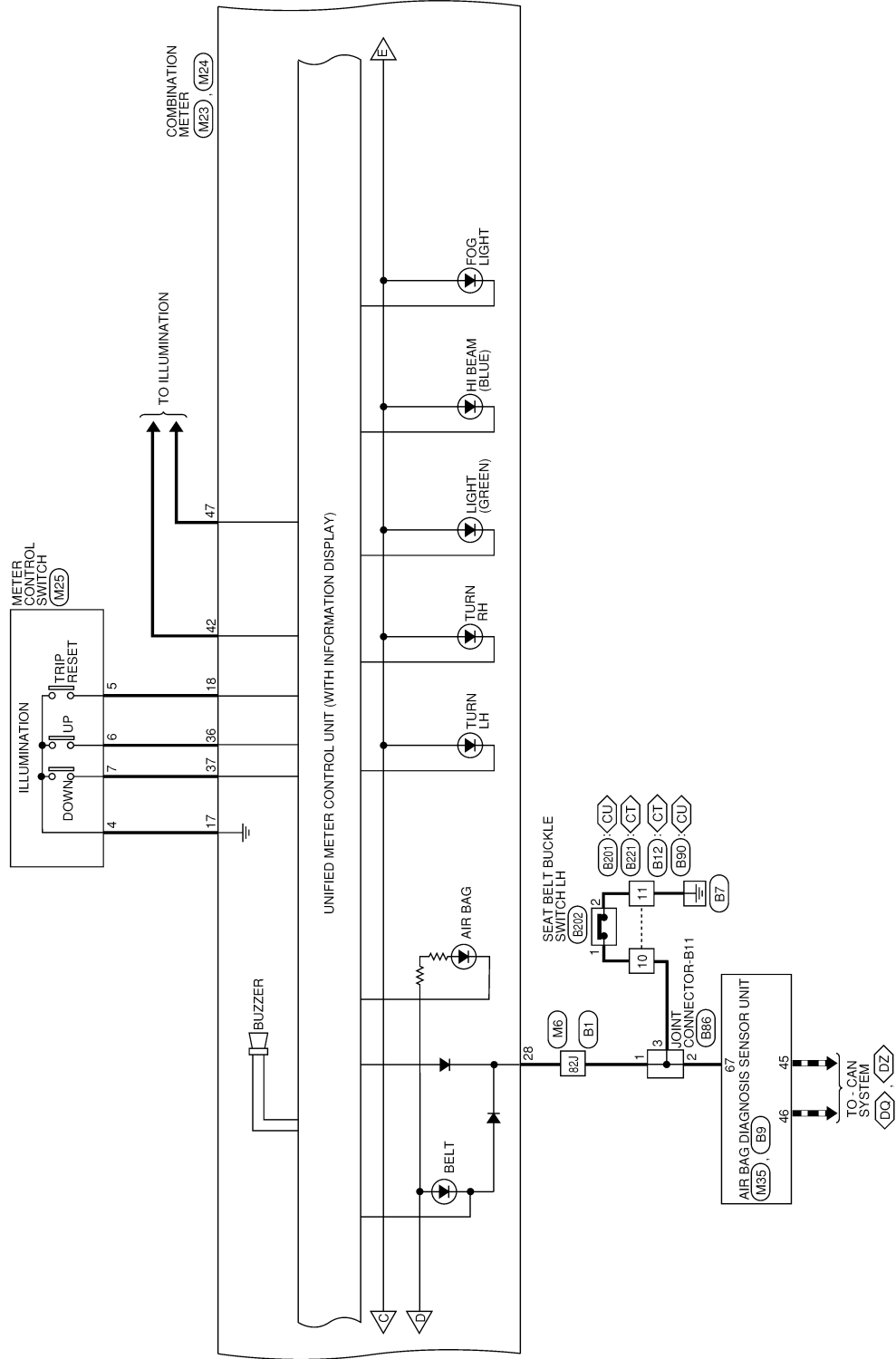

A
B
C
D
E
F
G
H
I
J
K
L
M
N
O
P

MWI

AANWA1390GB

METER SYSTEM

< WIRING DIAGRAM >

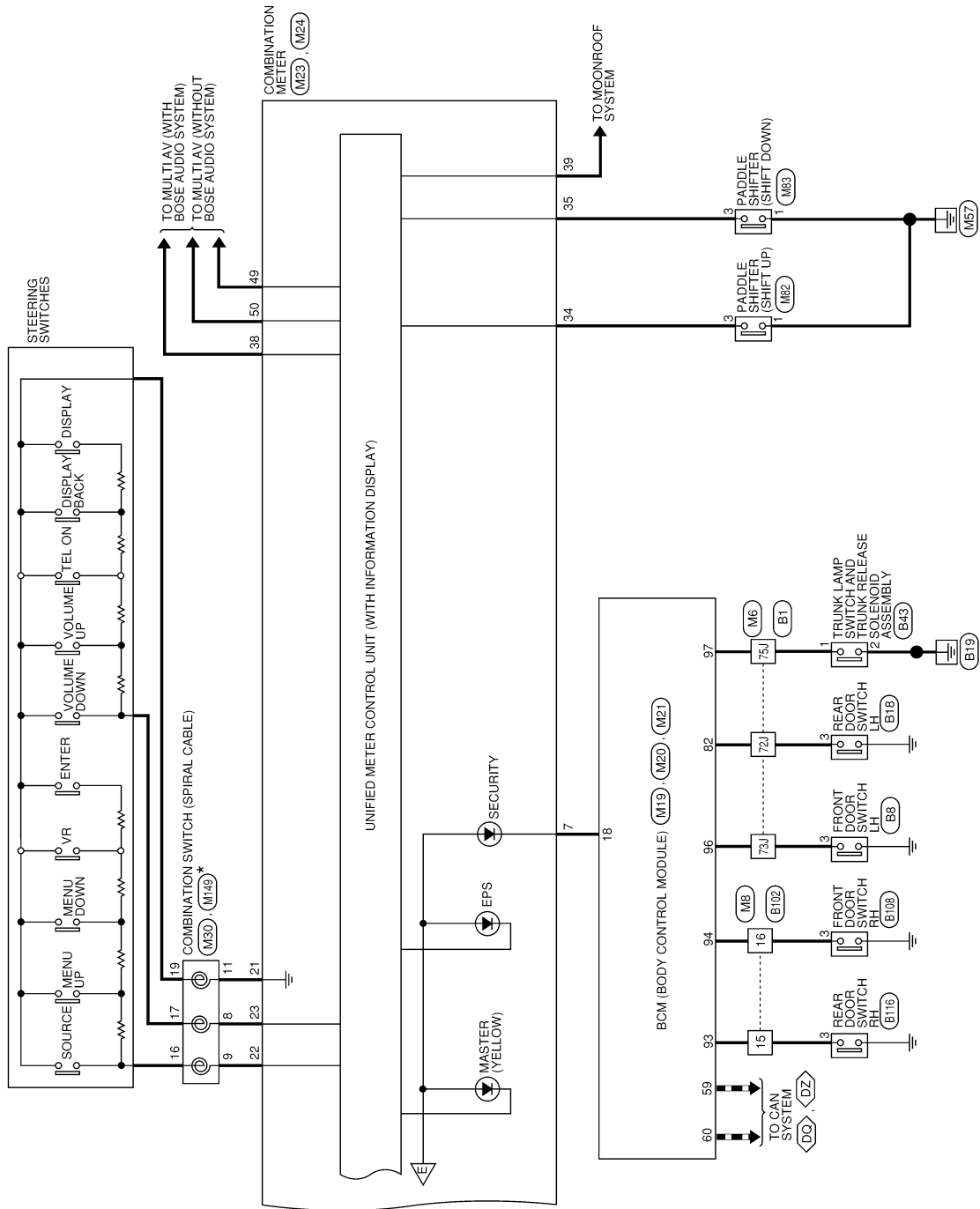

AANWA1391GB

METER SYSTEM

< WIRING DIAGRAM >

METER CONNECTORS

Connector No.	M1
Connector Name	WIRES TO WIRE
Connector Type	TH80FW-CS16-TM4
Connector Color	WHITE

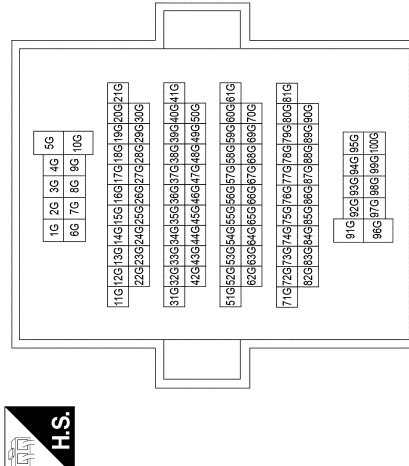

Terminal No.	Color of Wire	Signal Name
27G	R	-
28G	BR	-
29G	V	-
30G	BG	-

Connector No.	M4
Connector Name	FUSE BLOCK (J/B)
Connector Type	NS16FBR-CS
Connector Color	BROWN

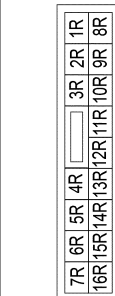

Terminal No.	Color of Wire	Signal Name
6R	P	-

Connector No.	M5
Connector Name	FUSE BLOCK (J/B)
Connector Type	NS16FW-CS
Connector Color	WHITE

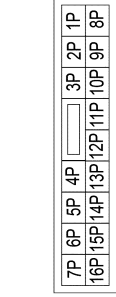

Terminal No.	Color of Wire	Signal Name
8P	BR	-
13P	G	-

Connector No.	M6
Connector Name	WIRES TO WIRE
Connector Type	TH80FDGY-CS16-TM4
Connector Color	GRAY

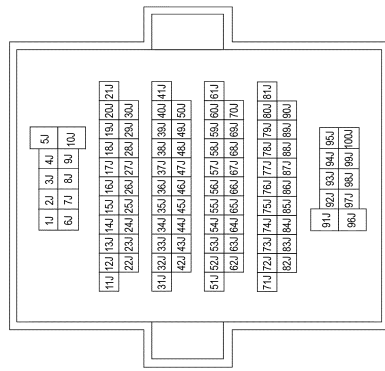

Terminal No.	Color of Wire	Signal Name
72J	Y	-
73J	P	-
75J	L	-
80J	W	-
81J	R	-
82J	LG	-

Connector No.	M8
Connector Name	WIRES TO WIRE
Connector Type	TH32FW-NH
Connector Color	WHITE

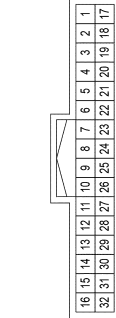

Terminal No.	Color of Wire	Signal Name
15	V	-
16	W	-

Connector No.	M19
Connector Name	BCM (BODY CONTROL MODULE)
Connector Type	TH24FGY-NH
Connector Color	GRAY

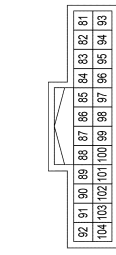

Terminal No.	Color of Wire	Signal Name
82	Y	RL DOOR SW
93	V	RR DOOR SW
94	W	AS DOOR SW
96	P	DR DOOR SW
97	L	TRUNK SW

A
B
C
D
E
F
G
H
I
J
K
L
M
N
O
P

MWI

AANIA4002GB

METER SYSTEM

< WIRING DIAGRAM >

27	-	-	-
28	LG	-	SEAT BELT SW (DR)
29	-	-	-
30	W	-	M RANGE
31	G	-	NOT M RANGE
32	P	-	AT SHIFT UP
33	BG	-	AT SHIFT DOWN
34	R	-	AT STRG SHIFT UP
35	W	-	AT STRG SHIFT DOWN
36	Y	-	ILL UP SW
37	SB	-	ILL DOWN SW
38	BG	-	SPEED 8PR OUT
39	P	-	SPEED 2PR OUT
40	-	-	-

Connector No.	M25
Connector Name	METER CONTROL SWITCH
Connector Type	TH08FW-NH
Connector Color	WHITE



1	2	3	4
5	6	7	8

Terminal No.	Color of Wire	Signal Name
4	G	-
5	V	-
6	Y	-
7	SB	-

Connector No.	M30
Connector Name	COMBINATION SWITCH (SPIRAL CABLE)
Connector Type	TK08FGY-1V
Connector Color	GRAY



10	9	8	7
14	13	12	11

Terminal No.	Color of Wire	Signal Name
8	G	-
9	P	-
11	W	-

45	B	GND2
46	G	POWER (BAT)
47	BG	INDIRECT ILL CONT OUT
48	R	FUEL SENSOR
49	LG	M-CAN (LOW)
50	SB	M-CAN (HI)
51	-	CAN-L
52	P	CAN-H
53	L	FUEL SENSOR GND
54	W	-
55	-	-
56	-	-

Connector No.	M24
Connector Name	COMBINATION METER
Connector Type	TH40FW-NH
Connector Color	WHITE



1	2	3	4	5	6	7	8	9	10	11	12	13	14	15	16	17	18	19	20
21	22	23	24	25	26	27	28	29	30	31	32	33	34	35	36	37	38	39	40

Terminal No.	Color of Wire	Signal Name
1	-	-
2	-	-
3	-	-
4	-	-
5	-	-
6	-	-
7	G	SECURITY
8	-	-
9	-	-
10	GR	INDIRECT ILLUMINATION SEMI-ACTIVE INPUT
11	R	CHARGE
12	BG	LED HEAD LAMP-R
13	W	LED HEAD LAMP-L
14	P	POWER (ACC)
15	-	-
16	-	-
17	G	GND (SATELLITE SW)
18	V	TRIP RESET SW
19	-	-
20	-	-
21	W	GND (STRG SW INPUT)
22	P	STRG SW (INPUT)
23	G	STRG SW (INPUT2)
24	BG	WASHER LEVEL SW
25	BR	BRAKE OIL SW
26	V	PKG SW

Connector No.	M20
Connector Name	BCM (BODY CONTROL MODULE)
Connector Type	TH40FB-NH
Connector Color	BLACK



60	59	58	57	56	55	54	53	52	51	50	49	48	47	46	45	44	43	42	41
80	79	78	77	76	75	74	73	72	71	70	69	68	67	66	65	64	63	62	61

Terminal No.	Color of Wire	Signal Name
59	P	CAN-L
60	L	CAN-H

Connector No.	M21
Connector Name	BCM (BODY CONTROL MODULE)
Connector Type	TH40FG-NH
Connector Color	GREEN



20	19	18	17	16	15	14	13	12	11	10	9	8	7	6	5	4	3	2	1
40	39	38	37	36	35	34	33	32	31	30	29	28	27	26	25	24	23	22	21

Terminal No.	Color of Wire	Signal Name
18	G	SECURITY INDICATOR

Connector No.	M23
Connector Name	COMBINATION METER
Connector Type	TH16FW-NH
Connector Color	WHITE



41	42	43	44	45	46	47	48
49	50	51	52	53	54	55	56

Terminal No.	Color of Wire	Signal Name
41	-	-
42	GR	ILL CONT OUT
43	B	GND1
44	BR	POWER (IGN)

AANIA4003GB

METER SYSTEM

< WIRING DIAGRAM >

Connector No.	E2
Connector Name	WIRE TO WIRE
Connector Type	TH24MW-NH
Connector Color	WHITE

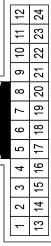

Terminal No.	4	Color of Wire	R	Signal Name	-
--------------	---	---------------	---	-------------	---

Connector No.	E3
Connector Name	WIRE TO WIRE
Connector Type	TH16MW-NH
Connector Color	WHITE



Terminal No.	7	Color of Wire	W	Signal Name	-
--------------	---	---------------	---	-------------	---

Connector No.	E10
Connector Name	ECM
Connector Type	RH24FB-RZ8-L-LH
Connector Color	BLACK

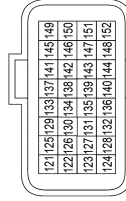

Terminal No.	123	Color of Wire	P	Signal Name	CAN-L
Terminal No.	124	Color of Wire	L	Signal Name	CAN-H

1	B	-
3	R	-

Connector No.	M83
Connector Name	PADDLE SHIFTER (SHIFT DOWN)
Connector Type	A03FW
Connector Color	WHITE

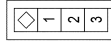

Terminal No.	1	Color of Wire	B	Signal Name	-
Terminal No.	3	Color of Wire	W	Signal Name	-

Connector No.	M149
Connector Name	COMBINATION SWITCH (SPIRAL CABLE)
Connector Type	TK08FGY-X
Connector Color	GRAY

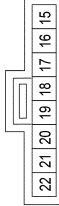

Terminal No.	16	Color of Wire	Y	Signal Name	-
Terminal No.	17	Color of Wire	G	Signal Name	-
Terminal No.	19	Color of Wire	L	Signal Name	-

Connector No.	M35
Connector Name	AIR BAG DIAGNOSIS SENSOR UNIT
Connector Type	NH28FY-EX
Connector Color	YELLOW

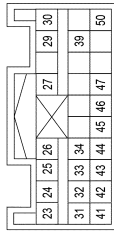

Terminal No.	45	Color of Wire	P	Signal Name	CAN-L
Terminal No.	46	Color of Wire	L	Signal Name	CAN-H

Connector No.	M78
Connector Name	CVT SHIFT SELECTOR
Connector Type	TH16FW-NH
Connector Color	WHITE

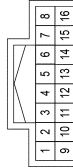

Terminal No.	7	Color of Wire	W	Signal Name	-
Terminal No.	8	Color of Wire	BG	Signal Name	-
Terminal No.	9	Color of Wire	P	Signal Name	-
Terminal No.	10	Color of Wire	G	Signal Name	-
Terminal No.	11	Color of Wire	B	Signal Name	-

Connector No.	M82
Connector Name	PADDLE SHIFTER (SHIFT UP)
Connector Type	A04FW
Connector Color	WHITE

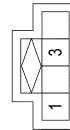

Terminal No.		Color of Wire		Signal Name	
--------------	--	---------------	--	-------------	--

AANIA4004GB

A
B
C
D
E
F
G
H
I
J
K
L
M
MWI
O
P

METER SYSTEM

< WIRING DIAGRAM >

Connector No.	F1
Connector Name	WIRE TO WIRE
Connector Type	TH16FW-NH
Connector Color	WHITE

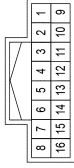

Terminal No.	7	Color of Wire	BR	Signal Name	-
--------------	---	---------------	----	-------------	---

Connector No.	F7
Connector Name	GENERATOR
Connector Type	HS03FB
Connector Color	BLACK

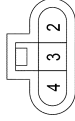

Terminal No.	2	Color of Wire	BR	Signal Name	-
--------------	---	---------------	----	-------------	---

Connector No.	F11
Connector Name	ENGINE COOLANT TEMPERATURE SENSOR
Connector Type	E02FGY-RS
Connector Color	GRAY

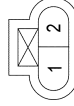

Terminal No.	1	Color of Wire	P	Signal Name	-
2	B				

Connector No.	E35
Connector Name	PARKING BRAKE SWITCH
Connector Type	P01FB-A
Connector Color	BLACK



Terminal No.	1	Color of Wire	L	Signal Name	-
--------------	---	---------------	---	-------------	---

Connector No.	E202
Connector Name	WIRE TO WIRE
Connector Type	TH24FW-NH
Connector Color	WHITE

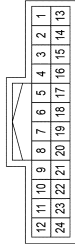

Terminal No.	4	Color of Wire	LG	Signal Name	-
--------------	---	---------------	----	-------------	---

Connector No.	E208
Connector Name	WASHER FLUID LEVEL SWITCH
Connector Type	PEX02FB
Connector Color	BLACK

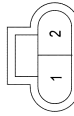

Terminal No.	1	Color of Wire	LG	Signal Name	-
2	B				

Connector No.	E24
Connector Name	BRAKE FLUID LEVEL SWITCH
Connector Type	YV02FGY
Connector Color	GRAY

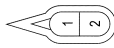

Terminal No.	1	Color of Wire	BG	Signal Name	-
2	GR				

Connector No.	E30
Connector Name	WIRE TO WIRE
Connector Type	TH80MW-CS16-TM4
Connector Color	WHITE

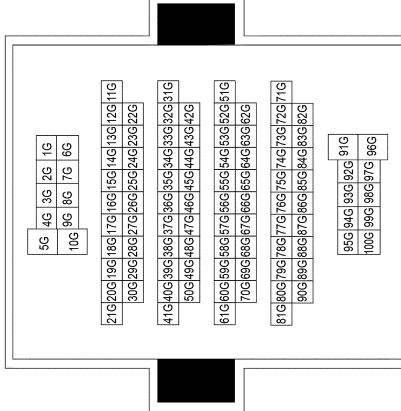

Terminal No.	27G	Color of Wire	W	Signal Name	-
28G	BG				
29G	L				
30G	R				

AANIA4005GB

METER SYSTEM

< WIRING DIAGRAM >

Connector No.	B8
Connector Name	FRONT DOOR SWITCH LH
Connector Type	TH04FW-NH
Connector Color	WHITE

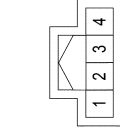

Terminal No.	Color of Wire	Signal Name
3	BR	-

Connector No.	B9
Connector Name	AIR BAG DIAGNOSIS SENSOR UNIT
Connector Type	NH22FY-2V-EX
Connector Color	YELLOW

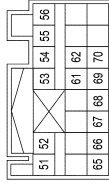

Terminal No.	Color of Wire	Signal Name
67	LG	LH SEAT BELT BUCKLE SWITCH+

Connector No.	B12
Connector Name	WIRE TO WIRE
Connector Type	NS12FW-CS
Connector Color	WHITE



Terminal No.	Color of Wire	Signal Name
10	LG	-
11	B	-

Connector No.	F80
Connector Name	ENGINE OIL PRESSURE SENSOR
Connector Type	RH03FB
Connector Color	BLACK

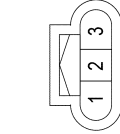

Terminal No.	Color of Wire	Signal Name
1	L	-
2	LG	-
3	R	-

Connector No.	B1
Connector Name	WIRE TO WIRE
Connector Type	TH80MDGY-CS16-TM4
Connector Color	GRAY

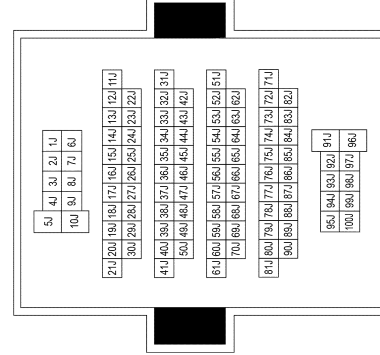

Terminal No.	Color of Wire	Signal Name
72J	Y	-
73J	BR	-
75J	W	-
80J	G	-
81J	W	-
82J	LG	-

Connector No.	F13
Connector Name	ECM
Connector Type	MAB35FB-MEB20-LH
Connector Color	BLACK

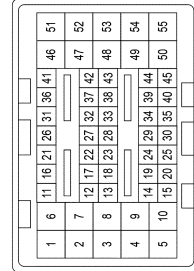

Terminal No.	Color of Wire	Signal Name
14	LG	ENGINE OIL PRESSURE SENSOR
15	L	SENSOR GROUND
18	R	SENSOR POWER SUPPLY
31	P	ENGINE COOLANT TEMPERATURE SENSOR
35	B	SENSOR GROUND

Connector No.	F71
Connector Name	JOINT CONNECTOR-F03
Connector Type	RH10FB
Connector Color	BLACK

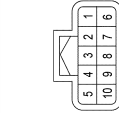

Terminal No.	Color of Wire	Signal Name
2	B	-
7	B	-

A
B
C
D
E
F
G
H
I
J
K
L
M
N
O
P

MWI

METER SYSTEM

< WIRING DIAGRAM >

15	V	-
16	SB	-

Connector No.	B108
Connector Name	FRONT DOOR SWITCH RH
Connector Type	TH04FW-NH
Connector Color	WHITE

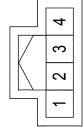
Terminal No.	3	Color of Wire	SB	Signal Name	-
--------------	---	---------------	----	-------------	---

Connector No.	B116
Connector Name	REAR DOOR SWITCH RH
Connector Type	TH04FW-NH
Connector Color	WHITE

Terminal No.	3	Color of Wire	V	Signal Name	-
--------------	---	---------------	---	-------------	---

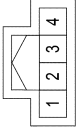
2	GR	-
---	----	---

Connector No.	B86
Connector Name	JOINT CONNECTOR-B11
Connector Type	TK04FW-J
Connector Color	WHITE

Terminal No.	1	Color of Wire	LG	Signal Name	-
2	LG	-	-	-	-
3	LG	-	-	-	-

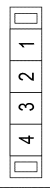
Connector No.	B90
Connector Name	WIRE TO WIRE
Connector Type	NS12FW-CS
Connector Color	WHITE

Terminal No.	10	Color of Wire	LG	Signal Name	-
11	B	-	-	-	-

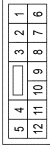
Connector No.	B102
Connector Name	WIRE TO WIRE
Connector Type	TH32MW-NH
Connector Color	WHITE

Terminal No.	-	Color of Wire	-	Signal Name	-
--------------	---	---------------	---	-------------	---

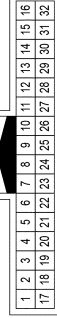
Connector No.	B18
Connector Name	REAR DOOR SWITCH LH
Connector Type	TH04FW-NH
Connector Color	WHITE

Terminal No.	3	Color of Wire	Y	Signal Name	-
--------------	---	---------------	---	-------------	---

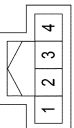
Connector No.	B42
Connector Name	FUEL LEVEL SENSOR UNIT AND FUEL PUMP
Connector Type	E06FGY-RS
Connector Color	GRAY

Terminal No.	2	Color of Wire	G	Signal Name	-
5	W	-	-	-	-

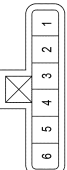
Connector No.	B43
Connector Name	TRUNK LAMP SWITCH AND TRUNK RELEASE SOLENOID ASSEMBLY
Connector Type	TB03FW-LC
Connector Color	WHITE

Terminal No.	1	Color of Wire	W	Signal Name	-
--------------	---	---------------	---	-------------	---

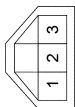
AANIA4007GB

METER SYSTEM

< WIRING DIAGRAM >

A
B
C
D
E
F
G
H
I
J
K
L
M
N
O
P

Connector No.	B201
Connector Name	WIRE TO WIRE
Connector Type	NS12MW-CS
Connector Color	WHITE



1	2	3	4	5
6	7	8	9	10
11	12			

Terminal No.	Color of Wire	Signal Name
10	L	-
11	B	-

Connector No.	B202
Connector Name	SEAT BELT BUCKLE SWITCH LH
Connector Type	TH04FW-NH
Connector Color	WHITE

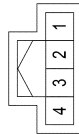

Terminal No.	Color of Wire	Signal Name
1	L	-
2	B	-

Connector No.	B221
Connector Name	WIRE TO WIRE
Connector Type	NS12MW-CS
Connector Color	WHITE



1	2	3	4	5
6	7	8	9	10
11	12			

Terminal No.	Color of Wire	Signal Name
10	-	-
11	B	-

AANIA4008GB



DIAGNOSIS AND REPAIR WORK FLOW

< BASIC INSPECTION >

BASIC INSPECTION

DIAGNOSIS AND REPAIR WORK FLOW

Work flow

INFOID:000000012227905

OVERALL SEQUENCE

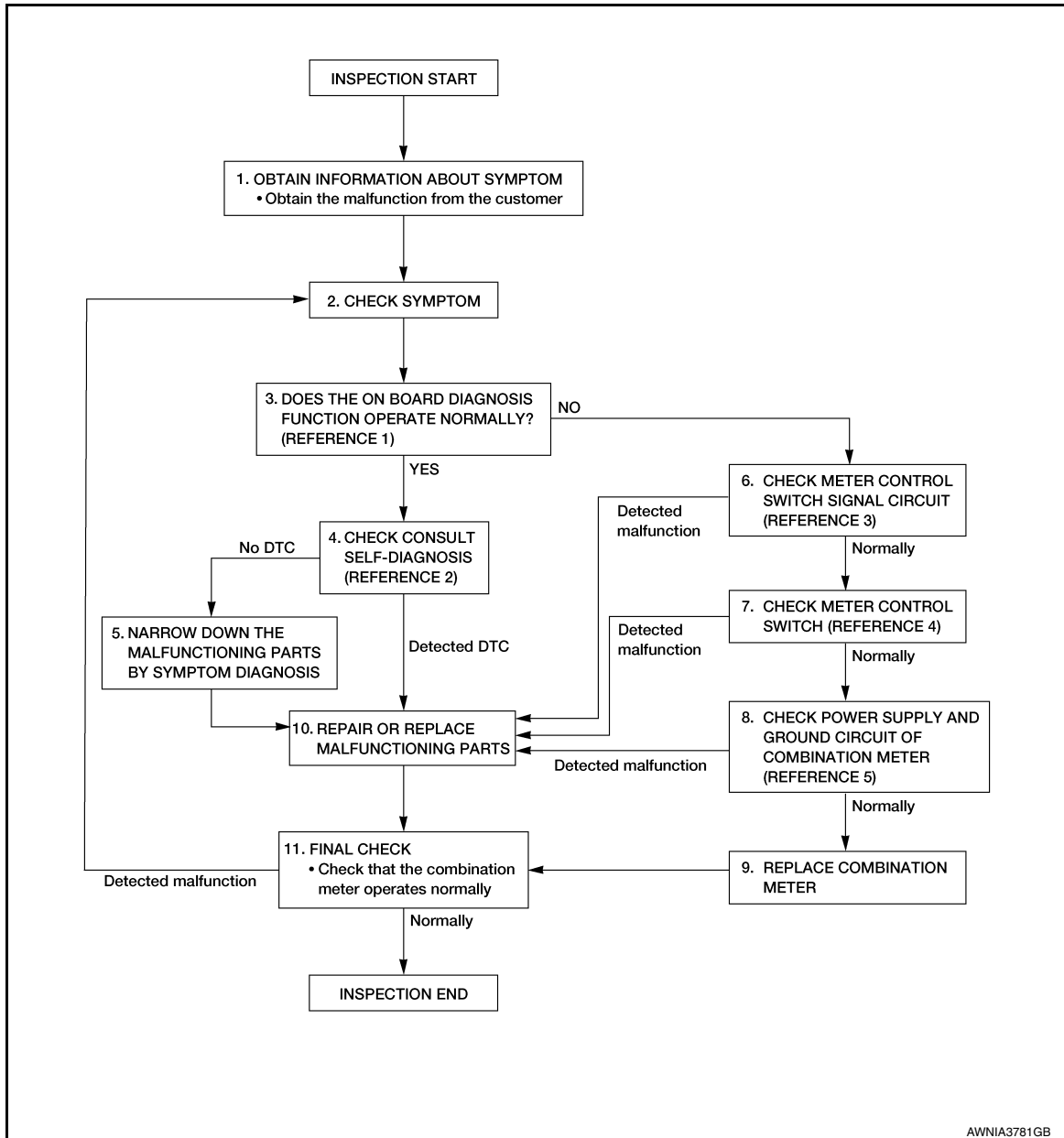

- Reference 1: [MWI-18. "On Board Diagnosis Function"](#)
- Reference 2: [MWI-29. "DTC Index"](#)
- Reference 3: [MWI-52. "Diagnosis Procedure"](#)
- Reference 4: [MWI-53. "Component Inspection"](#)
- Reference 5: [MWI-50. "COMBINATION METER : Diagnosis Procedure"](#)

DETAILED FLOW

1. OBTAIN INFORMATION ABOUT SYMPTOM

Interview the customer to obtain as much information as possible about the conditions and environment under which the malfunction occurred.

DIAGNOSIS AND REPAIR WORK FLOW

< BASIC INSPECTION >

>> GO TO 2.

2. CHECK SYMPTOM

- Check the symptom based on the information obtained from the customer.
- Check if any other malfunctions are present.

>> GO TO 3.

3. CHECK ON BOARD DIAGNOSIS OPERATION

Check that the on board diagnosis function operates. Refer to [MWI-18, "On Board Diagnosis Function"](#).

Is the inspection result normal?

YES >> GO TO 4.

NO >> GO TO 6.

4. CHECK CONSULT SELF-DIAGNOSIS RESULTS

1. Perform "Self Diagnostic Result". Refer to [MWI-29, "DTC Index"](#).
2. When DTC is detected, follow the instructions below:
 - Record DTC and Freeze Frame Data.

Is the inspection result normal?

YES >> GO TO 5.

NO >> GO TO 10.

5. NARROW DOWN THE MALFUNCTIONING PARTS BY SYMPTOM DIAGNOSIS

Perform symptom diagnosis and narrow down the malfunctioning parts.

>> GO TO 10.

6. CHECK METER CONTROL SWITCH SIGNAL CIRCUIT

Check meter control switch signal circuit. Refer to [MWI-52, "Diagnosis Procedure"](#).

Is the inspection result normal?

YES >> GO TO 7.

NO >> GO TO 10.

7. CHECK METER CONTROL SWITCH

Check meter control switch. Refer to [MWI-53, "Component Inspection"](#).

Is the inspection result normal?

YES >> GO TO 8.

NO >> GO TO 10.

8. CHECK COMBINATION METER POWER SUPPLY AND GROUND CIRCUITS

Check combination meter power supply and ground circuits. Refer to [MWI-50, "COMBINATION METER : Diagnosis Procedure"](#).

Is the inspection result normal?

YES >> GO TO 9.

NO >> GO TO 10.

9. REPLACE COMBINATION METER

Replace combination meter. Refer to [MWI-68, "Removal and Installation"](#).

>> GO TO 11.

10. REPAIR OR REPLACE MALFUNCTIONING PARTS

Repair or replace the malfunctioning parts.

NOTE:

If DTC is displayed, erase DTC after repairing or replacing malfunctioning parts.

>> GO TO 11.

A
B
C
D
E
F
G
H
I
J
K
L
M
O
P

MWI

DIAGNOSIS AND REPAIR WORK FLOW

< BASIC INSPECTION >

11.FINAL CHECK

Check that the combination meter operates normally.

Is the inspection result normal?

YES >> Inspection End.

NO >> GO TO 2.

U1000 CAN COMM CIRCUIT

< DTC/CIRCUIT DIAGNOSIS >

DTC/CIRCUIT DIAGNOSIS

U1000 CAN COMM CIRCUIT

DTC Description

INFOID:0000000012227906

Refer to [LAN-8, "System Description"](#).

DTC DETECTION LOGIC

DTC No.	CONSULT screen terms (Trouble diagnosis content)	DTC detection condition	
		Diagnosis condition	When ignition switch is ON.
U1000	CAN COMM CIRCUIT (CAN COMM CIRCUIT)	Signal (terminal)	-
		Threshold	When combination meter is not transmitting or receiving CAN communication signals
		Diagnosis delay time	2 seconds or more

POSSIBLE CAUSE

CAN communication system

FAIL-SAFE

The combination meter activates the fail-safe control if CAN communication with each unit is malfunctioning.

Refer to [MWI-28, "Fail-safe"](#).

DTC CONFIRMATION PROCEDURE

1.PERFORM SELF-DIAGNOSIS

CONSULT

1. Turn ignition switch ON and wait for 2 seconds or more.
2. Select "Self Diagnostic Result" mode of "METER/M&A".
3. Check DTC.

Is DTC detected?

- YES >> Refer to [MWI-45, "Diagnosis Procedure"](#).
NO >> Refer to [GI-41, "Intermittent Incident"](#).

Diagnosis Procedure

INFOID:0000000012227907

1.CHECK CAN COMMUNICATION SYSTEM

Check CAN communication system. Refer to [LAN-17, "Trouble Diagnosis Flow Chart"](#).

>> Inspection End.

MWI

U1010 CONTROL UNIT (CAN)

< DTC/CIRCUIT DIAGNOSIS >

U1010 CONTROL UNIT (CAN)

DTC Description

INFOID:000000012227908

DTC DETECTION LOGIC

DTC No.	CONSULT screen terms (Trouble diagnosis content)	DTC detection condition	
U1010	CONTROL UNIT (CAN) [CONTROL UNIT (CAN)]	Diagnosis condition	When Ignition switch is ON.
		Signal (terminal)	-
		Threshold	-
		Diagnosis delay time	2 seconds or more

POSSIBLE CAUSE

Combination meter

FAIL-SAFE

The combination meter activates the fail-safe control if CAN communication with each unit is malfunctioning. Refer to [MWI-28, "Fail-safe"](#).

DTC CONFIRMATION PROCEDURE

1.PERFORM SELF-DIAGNOSIS

CONSULT

1. Turn ignition switch ON.
2. Select "Self Diagnostic Result" mode of "METER/M&A".
3. Check DTC.

Is DTC detected?

- YES >> Refer to [MWI-46, "Diagnosis Procedure"](#).
NO >> Refer to [GI-41, "Intermittent Incident"](#).

Diagnosis Procedure

INFOID:000000012227909

1.REPLACE COMBINATION METER

Replace combination meter. Refer to [MWI-68, "Removal and Installation"](#).

>> Inspection End.

B2205 VEHICLE SPEED

< DTC/CIRCUIT DIAGNOSIS >

B2205 VEHICLE SPEED

DTC Description

INFOID:000000012227910

DTC DETECTION LOGIC

DTC No.	CONSULT screen terms (Trouble diagnosis content)	DTC detection condition	
		Diagnosis condition	When ignition switch is ON.
B2205	VEHICLE SPEED CIRC [VEHICLE SPEED CIRC]	Signal (terminal)	-
		Threshold	When an erroneous speed signal is received
		Diagnosis delay time	2 seconds or more

POSSIBLE CAUSE

- Wheel speed sensor
- ABS actuator and electric unit (control unit)

DTC CONFIRMATION PROCEDURE

1.PERFORM SELF-DIAGNOSIS

CONSULT

1. Turn ignition switch ON.
2. Select "Self Diagnostic Result" mode of "METER/M&A".
3. Check DTC.

Is DTC detected?

- YES >> Refer to [MWI-47, "Diagnosis Procedure"](#).
NO >> Inspection End.

Diagnosis Procedure

INFOID:000000012227911

1.PERFORM SELF DIAGNOSTIC RESULT

CONSULT

1. Turn ignition switch ON.
2. Select "Self Diagnostic Result" mode of "ABS".
3. Check DTC.

Is DTC detected?

- YES >> Perform diagnosis procedure on the detected DTC. Refer to [BRC-227, "DTC Index"](#) (with ICC) or [BRC-52, "DTC Index"](#) (without ICC).
NO >> Inspection End.

MWI

B2267 ENGINE SPEED

< DTC/CIRCUIT DIAGNOSIS >

B2267 ENGINE SPEED

DTC Description

INFOID:000000012227912

DTC DETECTION LOGIC

DTC No.	CONSULT screen terms (Trouble diagnosis content)	DTC detection condition	
		Diagnosis condition	When ignition switch is ON.
B2267	ENGINE SPEED [ENGINE SPEED]	Signal (terminal)	-
		Threshold	ECM continuously transmits abnormal engine speed signals
		Diagnosis delay time	2 seconds or more

POSSIBLE CAUSE

- Crankshaft position sensor
- ECM

DTC CONFIRMATION PROCEDURE

1.PERFORM SELF-DIAGNOSIS

CONSULT

1. Turn ignition switch ON.
2. Select "Self Diagnostic Result" mode of "METER/M&A".
3. Check DTC.

Is DTC detected?

- YES >> Refer to [MWI-48, "Diagnosis Procedure"](#).
NO >> Inspection End.

Diagnosis Procedure

INFOID:000000012227913

1.PERFORM SELF DIAGNOSTIC RESULT

CONSULT

1. Turn ignition switch ON.
2. Select "Self Diagnostic Result" mode of "ECM".
3. Check DTC.

Is DTC detected?

- YES >> Perform diagnosis procedure on the detected DTC. Refer to [EC-107, "DTC Index"](#).
NO >> Inspection End.

B2268 WATER TEMP

< DTC/CIRCUIT DIAGNOSIS >

B2268 WATER TEMP

DTC Description

INFOID:000000012227914

DTC DETECTION LOGIC

DTC No.	CONSULT screen terms (Trouble diagnosis content)	DTC detection condition	
		Diagnosis condition	When ignition switch is ON.
B2268	WATER TEMP [WATER temperature]	Signal (terminal)	-
		Threshold	ECM continuously transmits abnormal engine coolant temperature signals
		Diagnosis delay time	60 seconds or more

POSSIBLE CAUSE

- Engine coolant temperature sensor
- ECM

DTC CONFIRMATION PROCEDURE

1. PERFORM SELF-DIAGNOSIS

ⓂCONSULT

1. Turn ignition switch ON.
2. Select "Self Diagnostic Result" mode of "METER/M&A".
3. Check DTC.

Is DTC detected?

- YES >> Refer to [MWI-49, "Diagnosis Procedure"](#).
NO >> Inspection End.

Diagnosis Procedure

INFOID:000000012227915

1. PERFORM SELF DIAGNOSTIC RESULT

ⓂCONSULT

1. Turn ignition switch ON.
2. Select "Self Diagnostic Result" mode of "ECM".
3. Check DTC.

Is DTC detected?

- YES >> Perform diagnosis procedure on the detected DTC. Refer to [EC-107, "DTC Index"](#).
NO >> Inspection End.

A
B
C
D
E
F
G
H
I
J
K
L
M
O
P

MWI

POWER SUPPLY AND GROUND CIRCUIT

< DTC/CIRCUIT DIAGNOSIS >

POWER SUPPLY AND GROUND CIRCUIT COMBINATION METER

COMBINATION METER : Diagnosis Procedure

INFOID:000000012227916

Regarding Wiring Diagram information, refer to [MWI-31. "Wiring Diagram"](#).

1. CHECK FUSES

Check that the following fuses are not blown:

Unit	Power source	Fuse No.
Combination meter	Battery	13
	Ignition switch ON or ACC	21
	Ignition switch ON or START	31

Is the fuse blown?

YES >> Replace the blown fuse after repairing the affected circuit.

NO >> GO TO 2.

2. CHECK POWER SUPPLY CIRCUIT

1. Disconnect combination meter harness connectors M23 and M24.
2. Check voltage between combination meter harness connectors M23 and M24 and ground.

Combination meter		Ground	Ignition switch position		
Connector	Terminal		OFF	ON or ACC	START
M24	14	(-)	0 V	Battery voltage	Battery voltage
M23	44		0 V	Battery voltage	Battery voltage
	46		Battery voltage	Battery voltage	Battery voltage

Is the inspection result normal?

YES >> GO TO 3.

NO >> Repair or replace harness or connector.

3. CHECK GROUND CIRCUIT

1. Turn ignition switch OFF.
2. Check continuity between combination meter harness connector M23, M24 and ground.

Combination meter		Ground	Continuity
Connector	Terminal		
M24	10	(-)	Yes
M23	43		
	45		

Is the inspection result normal?

YES >> Inspection End.

NO >> Repair or replace harness or connector.

BCM (BODY CONTROL MODULE)

BCM (BODY CONTROL MODULE) : Diagnosis Procedure

INFOID:000000012250299

Regarding Wiring Diagram information, refer to [BCS-56. "Wiring Diagram"](#).

POWER SUPPLY AND GROUND CIRCUIT

< DTC/CIRCUIT DIAGNOSIS >

1. CHECK FUSE AND FUSIBLE LINK

Check if the following BCM fuses or fusible link are blown.

Signal name	Fuse and fusible link No.
Fusible link battery power	I (40A)
BCM battery fuse	1 (10A)

Is the fuse or fusible link blown?

YES >> Replace the blown fuse or fusible link after repairing the affected circuit.

NO >> GO TO 2.

2. CHECK POWER SUPPLY CIRCUIT

1. Turn ignition switch OFF.
2. Disconnect BCM connector M17.
3. Check voltage between BCM harness connector M17 and ground.

Terminals		Voltage (Approx.)
(+)	(-)	
BCM		Ground
Connector	Terminal	
M17	135	
	142	Battery voltage

Is the measurement normal?

YES >> GO TO 3.

NO >> Repair or replace harness.

3. CHECK GROUND CIRCUIT

Check continuity between BCM harness connector M17 and ground.

BCM		Ground	Continuity
Connector	Terminal		
M17	138		Yes
	132		

Is the inspection result normal?

YES >> Inspection End.

NO >> Repair or replace harness.

A
B
C
D
E
F
G
H
I
J
K
L
M
O
P

MWI

METER CONTROL SWITCH SIGNAL CIRCUIT

< DTC/CIRCUIT DIAGNOSIS >

METER CONTROL SWITCH SIGNAL CIRCUIT

Diagnosis Procedure

INFOID:000000012227918

Regarding Wiring Diagram information, refer to [MWI-31. "Wiring Diagram"](#).

1. CHECK METER CONTROL SWITCH SIGNAL

1. Turn ignition switch ON.
2. Check voltage between the following terminals of the meter control switch harness connector M25.

Meter control switch			Condition	Voltage (Approx.)
Connector	Terminals			
	(+)	(-)		
M25	7	4	When illumination control switch (-) is pressed	0 V
			Other than the above	5 V
	5		When trip reset switch is pressed	0 V
			Other than the above	5 V
	6		When illumination control switch (+) is pressed	0 V
			Other than the above	5 V

Is the inspection result normal?

- YES >> Inspection End.
 NO >> GO TO 2.

2. CHECK METER CONTROL SWITCH CIRCUITS

1. Turn ignition switch OFF.
2. Disconnect combination meter harness connector M24 and meter control switch harness connector M25.
3. Check continuity between combination meter harness connector M24 and meter control switch harness connector M25.

Combination meter		Meter control switch		Continuity
Connector	Terminal	Connector	Terminal	
M24	18	M25	5	Yes
	37		7	
	36		6	
	17		4	

4. Check continuity between combination meter harness connector M24 and ground.

Combination meter		Ground	Continuity
Connector	Terminal		
M24	18	Ground	No
	37		
	36		
	17		

Is the inspection result normal?

- YES >> Inspection End.
 NO >> Repair or replace harness or connector.

METER CONTROL SWITCH SIGNAL CIRCUIT

< DTC/CIRCUIT DIAGNOSIS >

Component Inspection

INFOID:000000012227919

1. CHECK METER CONTROL SWITCH

1. Turn ignition switch OFF.
2. Disconnect meter control switch harness connector.
3. Check meter control switch.

Meter control switch		Condition	Continuity
Terminals			
7	4	When illumination control switch (-) is pressed	Yes
		Other than the above	No
5		When trip reset switch is pressed	Yes
		Other than the above	No
6		When illumination control switch (+) is pressed	Yes
		Other than the above	No

Is the inspection result normal?

YES >> Inspection End.

NO >> Replace meter control switch. Refer to [MWI-69. "Removal and Installation"](#).

A
B
C
D
E
F
G
H
I
J
K
L
M
O
P



FUEL LEVEL SENSOR SIGNAL CIRCUIT

< DTC/CIRCUIT DIAGNOSIS >

FUEL LEVEL SENSOR SIGNAL CIRCUIT

Component Function Check

INFOID:000000012227920

1.COMBINATION METER INPUT SIGNAL

CONSULT

1. Select "Data Monitor" mode of "METER/M&A".
2. Select "FUEL METER".
3. Compare the "FUEL METER" value and the fuel gauge reading of the combination meter. Fuel gauge and data monitor indications should be close.

Combination meter	Monitor item
Fuel gauge	FUEL METER [L] (Approx.)
Full	67.1
3/4	53.2
1/2	37.3
1/4	21.9
Empty	7.3

Does the data monitor value approximately match the fuel gauge indication?

YES >> Inspection End.

NO >> Replace combination meter. Refer to [MWI-68, "Removal and Installation"](#).

Diagnosis Procedure

INFOID:000000012227921

Regarding Wiring Diagram information, refer to [MWI-31, "Wiring Diagram"](#).

1.CHECK HARNESS CONNECTOR

1. Turn ignition switch OFF.
2. Check combination meter and fuel level sensor unit and fuel pump (fuel level sensor) terminals (meter-side and harness-side) for poor connection.

Is the inspection result normal?

YES >> GO TO 2.

NO >> Repair or replace terminals or connectors.

2.CHECK FUEL LEVEL SENSOR CIRCUIT

1. Disconnect combination meter harness connector M23 and fuel level sensor unit and fuel pump (fuel level sensor) harness connector B42.
2. Check continuity between combination meter harness connector M23 and fuel level sensor unit and fuel pump (fuel level sensor) harness connector B42.

Fuel level sensor unit and fuel pump (fuel level sensor)		Combination meter		Continuity
Connector	Terminal	Connector	Terminal	
B42	5	M23	48	Yes

3. Check continuity between fuel level sensor unit and fuel pump (fuel level sensor) harness connector B42 and ground.

Fuel level sensor unit and fuel pump (fuel level sensor)		Ground	Continuity
Connector	Terminal		
B42	5		No

Is the inspection result normal?

FUEL LEVEL SENSOR SIGNAL CIRCUIT

< DTC/CIRCUIT DIAGNOSIS >

- YES >> GO TO 3.
 NO >> Repair or replace harness or connector.

3.CHECK FUEL LEVEL SENSOR GROUND CIRCUIT

1. Check continuity between combination meter harness connector M23 and fuel level sensor unit and fuel pump (fuel level sensor) harness connector B42.

Fuel level sensor unit and fuel pump (fuel level sensor)		Combination meter		Continuity
Connector	Terminal	Connector	Terminal	
B42	2	M23	54	Yes

2. Check continuity between fuel level sensor unit and fuel pump (fuel level sensor) harness connector B42 and ground.

Fuel level sensor unit and fuel pump (fuel level sensor)		Ground	Continuity
Connector	Terminal		
B42	2		No

Is the inspection result normal?

- YES >> GO TO 4.
 NO >> Repair or replace harness or connector.

4.CHECK INSTALLATION CONDITION

Check fuel level sensor unit installation, and check whether the float arm interferes or binds with any of the internal components in the fuel tank.

Is the inspection result normal?

- YES >> Inspection End.
 NO >> Install the fuel level sensor unit properly. Refer to [FL-5. "Removal and Installation"](#).

Component Inspection

INFOID:000000012227922

1.CHECK FUEL LEVEL SENSOR UNIT AND FUEL PUMP (FUEL LEVEL SENSOR)

1. Remove the fuel level sensor unit and fuel pump (fuel level sensor). Refer to [FL-5. "Removal and Installation"](#).
 2. Check the resistance between fuel level sensor unit and fuel pump (fuel level sensor) terminals.

Fuel level sensor unit and fuel pump (fuel level sensor)		Condition	Resistance (Ω) (Approx.)	Height [mm (in)]
Terminals				
2	5	Full* (A)	51	148.8 (5.9)
		Empty* (B)	283	32.2 (1.3)

*: When float rod is in contact with stopper.

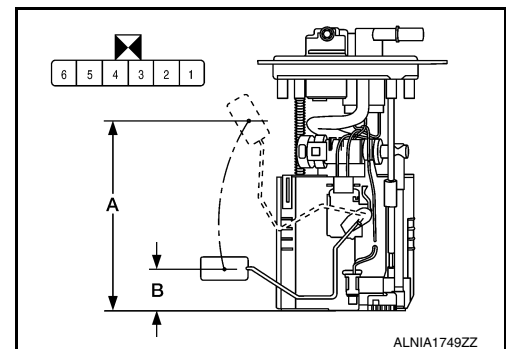

Is the inspection result normal?

- YES >> Inspection End.
 NO >> Replace fuel level sensor unit and fuel pump (fuel level sensor). Refer to [FL-5. "Removal and Installation"](#).

WASHER FLUID LEVEL SWITCH CIRCUIT

< DTC/CIRCUIT DIAGNOSIS >

WASHER FLUID LEVEL SWITCH CIRCUIT

Diagnosis Procedure

INFOID:000000012227923

Regarding Wiring Diagram information, refer to [MWI-31, "Wiring Diagram"](#).

1. CHECK WASHER FLUID LEVEL SWITCH SIGNAL CIRCUIT

1. Turn ignition switch OFF.
2. Disconnect combination meter harness connector M24 and washer fluid level switch harness connector E208.
3. Check continuity between combination meter harness connector M24 and washer fluid level switch harness connector E208.

Combination meter		Washer fluid level switch		Continuity
Connector	Terminal	Connector	Terminal	
M24	24	E208	1	Yes

4. Check continuity between combination meter harness connector M24 and ground.

Combination meter		Ground	Continuity
Connector	Terminal		
M24	24		No

Is the inspection result normal?

YES >> GO TO 2.

NO >> Repair or replace harness or connector.

2. CHECK WASHER FLUID LEVEL SWITCH GROUND CIRCUIT

Check continuity between washer fluid level switch harness connector E208 and ground.

Washer fluid level switch		Ground	Continuity
Connector	Terminal		
E208	2		Yes

Is the inspection result normal?

YES >> Inspection End.

NO >> Repair or replace harness or connector.

Component Inspection

INFOID:000000012227924

1. CHECK WASHER FLUID LEVEL SWITCH

1. Turn ignition switch OFF.
2. Disconnect washer fluid level switch connector.
3. Check washer fluid level switch.

Washer fluid level switch		Condition	Continuity
Terminals			
1	2	Washer fluid level switch ON	Yes
		Washer fluid level switch OFF	No

Is the inspection result normal?

YES >> Inspection End.

NO >> Replace washer fluid level switch. Refer to [WW-6, "Component Parts Location"](#).

STEERING SWITCH

< DTC/CIRCUIT DIAGNOSIS >

STEERING SWITCH

Diagnosis Procedure

INFOID:000000012227925

Regarding Wiring Diagram information, refer to [MWI-31, "Wiring Diagram"](#).

1. CHECK STEERING SWITCH CIRCUIT

1. Turn ignition switch OFF.
2. Disconnect combination meter harness connector M24 and spiral cable harness connector M30.
3. Check continuity between combination meter harness connector M24 and spiral cable harness connector M30.

Combination meter		Spiral cable		Continuity
Connector	Terminal	Connector	Terminal	
M24	21	M30	11	Yes
	22		9	
	23		8	

4. Check continuity between combination meter harness connector M24 and ground.

Combination meter		Ground	Continuity
Connector	Terminal		
M24	21	Ground	No
	22		
	23		

Is the inspection result normal?

- YES >> Inspection End.
 NO >> Repair or replace harness or connector.

Component Inspection

INFOID:000000012227926

1. CHECK STEERING SWITCH RESISTANCE

Check resistance between the following steering switch terminals:

Steering switches		Condition	Resistance (Ω) (Approx.)
Terminals	Signal name		
17	Display	Depress ▷ switch.	2023
	Back	Depress ◁ switch.	723
16	19 Enter	Depress OK switch.	2023
	Menu Up	Depress △ switch.	121
	Menu Down	Depress ▽ switch.	321

Is the inspection result normal?

- YES >> GO TO 2.
 NO >> Replace steering wheel switch. Refer to [AV-184, "Removal and Installation"](#).

2. CHECK SPIRAL CABLE

Check continuity between the following spiral cable terminals:

A
B
C
D
E
F
G
H
I
J
K
L
M
O
P

MWI

STEERING SWITCH

< DTC/CIRCUIT DIAGNOSIS >

Spiral cable		Continuity
Terminals		
16	9	Yes
17	8	
19	11	

Is the inspection result normal?

YES >> Inspection End.

NO >> Replace spiral cable. Refer to [SR-16. "Removal and Installation"](#).

THE FUEL GAUGE INDICATOR DOES NOT OPERATE

< SYMPTOM DIAGNOSIS >

SYMPTOM DIAGNOSIS

THE FUEL GAUGE INDICATOR DOES NOT OPERATE

Description

INFOID:0000000012227927

Fuel gauge will not indicate from a certain position.

Diagnosis Procedure

INFOID:0000000012227928

1.PERFORM COMBINATION METER SELF-DIAGNOSIS MODE

Perform the self-diagnosis mode of combination meter, and then check that the fuel gauge operates normally. Refer to [MWI-18, "On Board Diagnosis Function"](#).

Is the inspection result normal?

YES >> GO TO 2.

NO >> Replace the combination meter. Refer to [MWI-68, "Removal and Installation"](#).

2.CHECK COMBINATION METER INPUT SIGNAL

Perform component function check. Refer to [MWI-54, "Component Function Check"](#).

Does data monitor value match fuel gauge reading?

YES >> GO TO 3.

NO >> Replace combination meter. Refer to [MWI-68, "Removal and Installation"](#).

3.CHECK FUEL LEVEL SENSOR UNIT CIRCUITS

Check the fuel level sensor circuits. Refer to [MWI-54, "Diagnosis Procedure"](#).

Is the inspection result normal?

YES >> GO TO 4.

NO >> Repair or replace harness or connector.

4.CHECK FUEL LEVEL SENSOR UNIT

Check the fuel level sensor unit. Refer to [MWI-55, "Component Inspection"](#).

Is the inspection result normal?

YES >> GO TO 5.

NO >> Replace fuel level sensor unit. Refer to [FL-5, "Removal and Installation"](#).

5.CHECK FLOAT INTERFERENCE

Check that the float arm does not interfere with or bind to other components in the fuel tank.

Is the inspection result normal?

YES >> Check intermittent incident. Refer to [GI-41, "Intermittent Incident"](#).

NO >> Repair or replace malfunctioning parts.

A
B
C
D
E
F
G
H
I
J
K
L
M
O
P

MWI

THE METER CONTROL SWITCH IS INOPERATIVE

< SYMPTOM DIAGNOSIS >

THE METER CONTROL SWITCH IS INOPERATIVE

Description

INFOID:000000012227929

The meter control switches are inoperative when pressed.

Diagnosis Procedure

INFOID:000000012227930

1.CHECK METER CONTROL SWITCH

Check the meter control switch. Refer to [MWI-53, "Component Inspection"](#).

Is the inspection result normal?

YES >> GO TO 2.

NO >> Replace meter control switch. Refer to [MWI-69, "Removal and Installation"](#).

2.CHECK METER CONTROL SWITCH SIGNAL

Check the meter control switch signal. Refer to [MWI-52, "Diagnosis Procedure"](#).

Is the inspection result normal?

YES >> Replace combination meter. Refer to [MWI-68, "Removal and Installation"](#).

NO >> Repair or replace harness or connector.

THE OIL PRESSURE WARNING CONTINUES DISPLAYING, OR DOES NOT DISPLAY

< SYMPTOM DIAGNOSIS >

THE OIL PRESSURE WARNING CONTINUES DISPLAYING, OR DOES NOT DISPLAY

Description

INFOID:000000012227931

- The low oil pressure warning message stays on when oil pressure is normal.
- The low oil pressure warning message stays off when oil pressure is low.

Diagnosis Procedure

INFOID:000000012227932

1. CHECK COMBINATION METER INPUT

CONSULT

1. Start the engine.
2. Select "Data Monitor" mode of "METER/M&A".
3. Select "OIL W/L".
4. Check that the function operates normally according to the following conditions:

Monitor item	Condition	CONSULT
OIL W/L	Engine running	Off

Is the inspection result normal?

- YES >> Perform "Self Diagnostic Result" of "ECM". Refer to [EC-73, "CONSULT Function"](#).
NO >> Replace combination meter. Refer to [MWI-68, "Removal and Installation"](#).

A
B
C
D
E
F
G
H
I
J
K
L
M
O
P

MWI

THE PARKING BRAKE RELEASE WARNING CONTINUES DISPLAYING, OR DOES NOT DISPLAY

< SYMPTOM DIAGNOSIS >

THE PARKING BRAKE RELEASE WARNING CONTINUES DISPLAYING, OR DOES NOT DISPLAY

Description

INFOID:000000012227933

- The parking brake warning is displayed during vehicle travel, even though the parking brake is released.
- The parking brake warning is not displayed, even while driving the vehicle with the parking brake applied.

Diagnosis Procedure

INFOID:000000012227934

1. CHECK PARKING BRAKE WARNING LAMP OPERATION

1. Start engine.
2. Check the operation of the brake warning lamp while operating the parking brake.

Condition	Warning lamp status
Parking brake applied	ON
Parking brake released	OFF

Is the inspection result normal?

- YES >> Inspection End.
NO >> GO TO 2.

2. CHECK PARKING BRAKE SWITCH SIGNAL CIRCUIT

1. Turn ignition switch OFF.
2. Check the parking brake switch signal circuit. Refer to [WCS-30, "Diagnosis Procedure"](#).

Is the inspection result normal?

- YES >> GO TO 3.
NO >> Repair or replace harness or connector.

3. CHECK PARKING BRAKE SWITCH UNIT

Check the parking brake switch. Refer to [WCS-30, "Component Inspection"](#).

Is the inspection result normal?

- YES >> Replace combination meter. Refer to [MWI-68, "Removal and Installation"](#).
NO >> Replace parking brake switch. Refer to [PB-11, "Removal and Installation"](#).

THE LOW WASHER FLUID WARNING CONTINUES DISPLAYING, OR DOES NOT DISPLAY

< SYMPTOM DIAGNOSIS >

THE LOW WASHER FLUID WARNING CONTINUES DISPLAYING, OR DOES NOT DISPLAY

Description

INFOID:000000012227935

- The warning is still displayed even after washer fluid is added.
- The warning is not displayed even though the washer tank is empty.

Diagnosis Procedure

INFOID:000000012227936

1.CHECK WASHER FLUID LEVEL SWITCH SIGNAL CIRCUIT

Check the washer fluid level switch signal circuit. Refer to [MWI-56. "Diagnosis Procedure"](#).

Is the inspection result normal?

- YES >> GO TO 2.
- NO >> Repair or replace harness or connector.

2.CHECK WASHER FLUID LEVEL SWITCH UNIT

Check the washer fluid level switch. Refer to [MWI-56. "Component Inspection"](#).

Is the inspection result normal?

- YES >> Replace combination meter. Refer to [MWI-68. "Removal and Installation"](#).
- NO >> Replace washer fluid level switch. Refer to [WW-53. "Removal and Installation"](#).

A
B
C
D
E
F
G
H
I
J
K
L
M
O
P

MWI

THE DOOR OPEN WARNING CONTINUES DISPLAYING, OR DOES NOT DISPLAY

< SYMPTOM DIAGNOSIS >

THE DOOR OPEN WARNING CONTINUES DISPLAYING, OR DOES NOT DISPLAY

Description

INFOID:000000012227937

- The door open warning is displayed even though all of the doors are closed.
- The door open warning is not displayed even though a door is ajar.

Diagnosis Procedure

INFOID:000000012227938

1. CHECK BCM INPUT SIGNAL

Check the BCM input signal. Refer to [DLK-98. "Component Function Check"](#).

Is the inspection result normal?

- YES >> GO TO 2.
- NO >> GO TO 3.

2. CHECK COMBINATION METER INPUT SIGNAL

CONSULT

1. Select "Data Monitor" mode of "METER/M&A".
2. Select "DOOR W/L".
3. Check that the function operates normally according to the following conditions:

Monitor item	Condition	Status
DOOR W/L	Door open	On
	Door closed	Off

Is the inspection result normal?

- YES >> Replace combination meter. Refer to [MWI-68. "Removal and Installation"](#).
- NO >> Replace BCM. Refer to [BCS-82. "Removal and Installation"](#).

3. CHECK DOOR SWITCH SIGNAL CIRCUIT

Check the door switch signal circuit. Refer to [DLK-98. "Diagnosis Procedure"](#).

Is the inspection result normal?

- YES >> GO TO 4.
- NO >> Repair or replace harness or connector.

4. CHECK DOOR SWITCH

Check the door switch. Refer to [DLK-99. "Component Inspection"](#).

Is the inspection result normal?

- YES >> Replace combination meter. Refer to [MWI-68. "Removal and Installation"](#).
- NO >> Replace applicable door switch. Refer to [DLK-197. "Removal and Installation"](#).

THE TRUNK OPEN WARNING CONTINUES DISPLAYING, OR DOES NOT DISPLAY

< SYMPTOM DIAGNOSIS >

THE TRUNK OPEN WARNING CONTINUES DISPLAYING, OR DOES NOT DISPLAY

Description

INFOID:000000012227939

- The trunk open warning is displayed continuously even though the trunk is closed.
- The trunk open warning is not displayed even though the trunk is open.

Diagnosis Procedure

INFOID:000000012227940

1. CHECK BCM INPUT SIGNAL

Check the BCM input signal. Refer to [DLK-133, "Component Function Check"](#).

Is the inspection result normal?

- YES >> GO TO 2.
- NO >> GO TO 3.

2. CHECK COMBINATION METER INPUT SIGNAL

CONSULT

1. Select "Data Monitor" mode of "METER/M&A".
2. Select "TRUNK/GLAS-H".
3. Check that the function operates normally according to the following conditions:

Monitor item	Condition	Status
TRUNK/GLAS-H	Trunk open	On
	Trunk closed	Off

Is the inspection result normal?

- YES >> Replace combination meter. Refer to [MWI-68, "Removal and Installation"](#).
- NO >> Replace BCM. Refer to [BCS-82, "Removal and Installation"](#).

3. CHECK TRUNK LAMP SWITCH SIGNAL CIRCUIT

Check the trunk lamp switch signal circuit. Refer to [DLK-133, "Diagnosis Procedure"](#).

Is the inspection result normal?

- YES >> GO TO 4.
- NO >> Repair or replace harness or connector.

4. CHECK TRUNK LAMP SWITCH

Check the trunk lamp switch. Refer to [DLK-134, "Component Inspection"](#).

Is the inspection result normal?

- YES >> Replace combination meter. Refer to [MWI-68, "Removal and Installation"](#).
- NO >> Replace trunk lamp switch. Refer to [DLK-190, "TRUNK LAMP SWITCH AND TRUNK RELEASE SOLENOID : Removal and Installation"](#).

MWI

THE STEERING SWITCHES ARE INOPERATIVE

< SYMPTOM DIAGNOSIS >

THE STEERING SWITCHES ARE INOPERATIVE

Description

INFOID:000000012227941

One or more of the steering switches to control the information display are inoperative.

Diagnosis Procedure

INFOID:000000012227942

1.CHECK STEERING SWITCH CIRCUIT

Check steering switch circuit. Refer to [MWI-57, "Diagnosis Procedure"](#).

Is the inspection result normal?

YES >> GO TO 2.

NO >> Repair or replace harness or connector.

2.CHECK STEERING SWITCH RESISTANCE

Check steering switch resistance. Refer to [MWI-57, "Component Inspection"](#).

Is the inspection result normal?

YES >> GO TO 3.

NO >> Replace steering switch. Refer to [AV-184, "Removal and Installation"](#).

3.CHECK SPIRAL CABLE

Check spiral cable for continuity. Refer to [MWI-57, "Component Inspection"](#).

Is the inspection result normal?

YES >> Replace combination meter. Refer to [MWI-68, "Removal and Installation"](#).

NO >> Replace spiral cable. Refer to [SR-16, "Removal and Installation"](#).

THE AMBIENT TEMPERATURE DISPLAY IS INCORRECT

< SYMPTOM DIAGNOSIS >

THE AMBIENT TEMPERATURE DISPLAY IS INCORRECT

Description

INFOID:000000012227943

- The displayed outside air temperature is higher than the actual temperature.
- The displayed outside air temperature is lower than the actual temperature.
- Outside air temperature is not indicated.

Diagnosis Procedure

INFOID:000000012227944

1. CHECK AMBIENT SENSOR SIGNAL CIRCUIT

Check the ambient sensor signal circuit. Refer to [HAC-59, "Diagnosis Procedure"](#).

Is the inspection result normal?

YES >> GO TO 2.

NO >> Repair or replace harness or connector.

2. CHECK AMBIENT SENSOR

Check the ambient sensor. Refer to [HAC-61, "Component Inspection"](#).

Is the inspection result normal?

YES >> Replace combination meter. Refer to [MWI-68, "Removal and Installation"](#).

NO >> Replace ambient sensor. Refer to [HAC-103, "Removal and Installation"](#).

A
B
C
D
E
F
G
H
I
J
K
L
M
O
P

MWI

COMBINATION METER

< REMOVAL AND INSTALLATION >

REMOVAL AND INSTALLATION

COMBINATION METER

Exploded View

INFOID:000000012227945

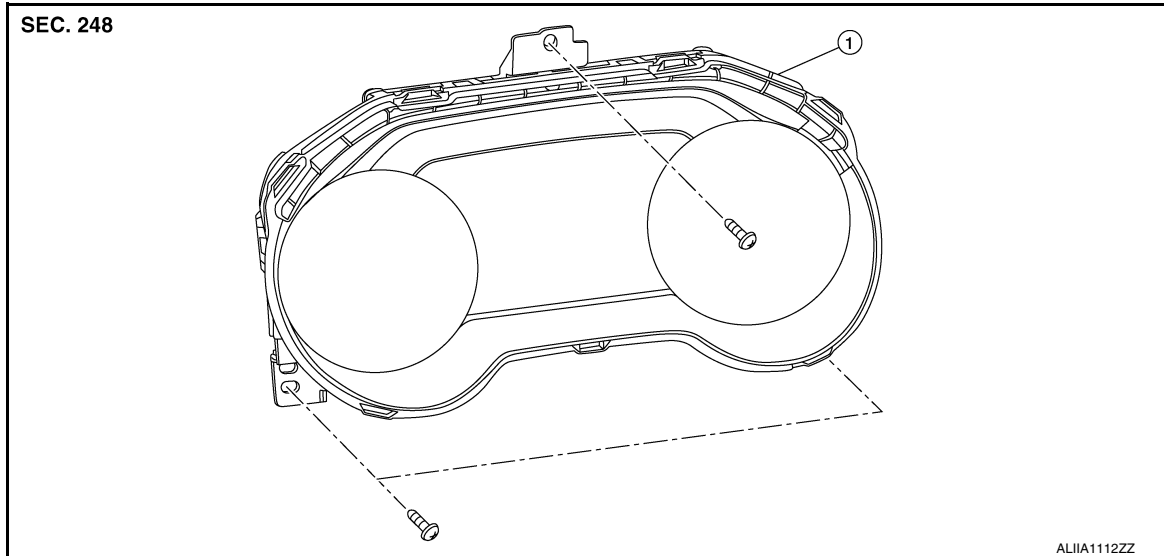

1. Combination meter

Removal and Installation

INFOID:000000012227946

REMOVAL

1. Remove cluster lid A. Refer to [IP-22, "Removal and Installation"](#).
2. Remove combination meter screws.
3. Pull out combination meter.
4. Disconnect harness connector from combination meter.
5. Remove combination meter.

INSTALLATION

Installation is in the reverse order of removal.

METER CONTROL SWITCH

< REMOVAL AND INSTALLATION >

METER CONTROL SWITCH

Removal and Installation

INFOID:000000012227947

REMOVAL

1. Remove instrument finisher A (1). Refer to [JP-16. "INSTRUMENT FINISHER A : Removal and Installation"](#).
2. Remove screws from the meter control switch (2) and remove.

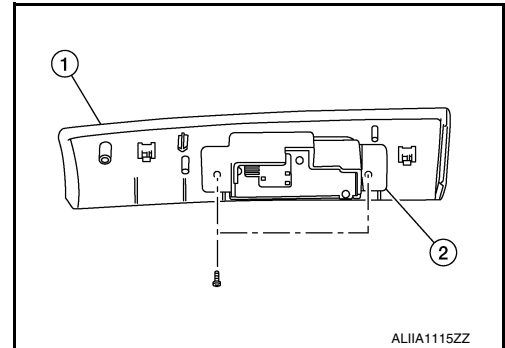

INSTALLATION

Installation is in the reverse order of removal.

A
B
C
D
E
F
G
H
I
J
K
L
M
O
P

MWI

COMBINATION METER

< UNIT DISASSEMBLY AND ASSEMBLY >

UNIT DISASSEMBLY AND ASSEMBLY

COMBINATION METER

Disassembly and Assembly

INFOID:000000011935785

DISASSEMBLY

1. Remove the combination meter. Refer to [MWI-68. "Removal and Installation"](#).
2. Release the combination meter lens (1) pawls from the combination meter (2) using a suitable tool and remove.

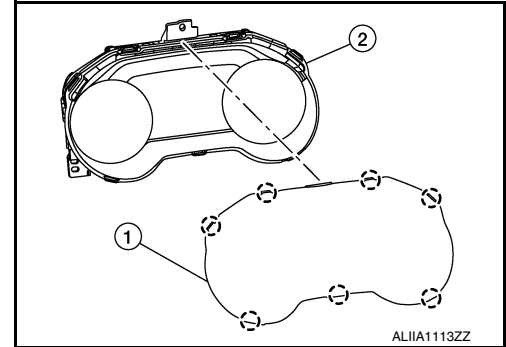

ASSEMBLY

Assembly is in the reverse order of disassembly.